

New Modality Issues: DICOM Enhanced Images CT, MR, PET, XA/XRF

Dr. David A. Clunie, MB.,BS., FRACR

Chief Technology Officer

RadPharm, Inc.

Disclosures

- David Clunie, MBBS, FRACR
 - *CTO, RadPharm, Inc. (formerly Princeton Radiology Pharmaceutical Research)*
 - *PixelMed Publishing - contractor for the NEMA Enhanced CT and MR test tools and images*

Acknowledgments

- *Kees Verduin, Philips Medical Systems*
- *Robert Haworth, GE Healthcare*
- *Charles Parisot, GE Healthcare*
- *Bernhard Hassold, Siemens Medical Solutions*
- *Bradley J Erickson, Mayo Clinic*

Acquisition - Standards

- Proprietary connections
 - Not scalable
 - Too expensive
 - Single vendor for PACS and all modalities implausible
- 1983 ACR-NEMA Committee
 - American College of Radiology
 - National Electrical Manufacturer's Association
- 1985 ACR-NEMA Version 1.0
- 1988 ACR-NEMA Version 2.0
- 50 pin plug point-to-point interface (no network, no files)
- Tag-value pairs of data elements
 - Describing acquisition and identifying patient

Acquisition - Standards

- Post-ACR-NEMA PACS and Modalities
 - Several vendors used ACR-NEMA ideas in proprietary networks
 - Siemens-Philips SPI
 - ACR-NEMA as a file format
- 1982 Interfile for Nuclear Medicine
 - AAPM
 - European COST-B2 project
- By 1990's still no widely adopted standard for
 - Specific modality requirements for all modalities
 - Network based transport and services

Acquisition - DICOM

- 1993 - Digital Imaging and Communications in Medicine
- Network-based
 - TCP/IP over Ethernet
- Services for
 - Storage (transfer)
 - Query and retrieval
 - Printing
- Derived from ACR-NEMA
- Added concepts of modality-specific information objects
- Conformance requirements and statement
- Interchange file format and media quickly added (1995)

1993 DICOM Image Objects

- Computed Radiography
- Computed Tomography
- Magnetic Resonance Imaging
- Nuclear Medicine
- Ultrasound
- Secondary Capture

2006 DICOM Image Objects

- Computed Radiography
- Computed Tomography
- Magnetic Resonance Imaging
- Nuclear Medicine
- Ultrasound
- Secondary Capture
- X-Ray Angiography
- X-Ray Fluoroscopy
- Positron Emission Tomography
- Radiotherapy (RT) Image
- Hardcopy Image
- Digital X-Ray
- Digital Mammography
- Intra-oral Radiography
- Visible Light Endoscopy & Video
- VL Photography & Video
- Visible Light Microscopy
- Multi-frame Secondary Capture
- Enhanced MR
- MR Spectroscopy
- Raw Data
- Enhanced CT
- Enhanced XA/XRF
- Ophthalmic Photography

2006 DICOM Non-Images

- Radiotherapy (RT) Structure Set, Plan, Dose, Treatment Record
- Waveforms (ECG, Hemodynamic, Audio)
- Grayscale, Color and Blending Presentation States
- Structured Reports
- Key Object Selection
- Mammography and Chest Computer Assisted Detection (CAD)
- Procedure Log
- Spatial Registration (Rigid and Deformable) and Fiducials
- Stereometric Relationship
- Segmentation

DICOM Challenges

- Expansion of scope
 - From images to workflow, reporting, therapy ...
- Evolution of modality technology
 - Speed and resolution of CT
 - Pulse sequences, gradients and field strength in MR
- Evolution of clinical applications
 - Enabled by technology
 - Enabled by contrast agents and radionuclides

DICOM Challenges

- More information
- More slices
- More complex applications on workstation
- Greater expectations of inter-functionality between different vendors modalities and workstations

What is *Inter-operability* ?

- Analogy of web server/browser:
 - Inter-connectivity - both talk TCP/IP
 - Inter-operability - both talk HTTP and HTML
 - Inter-functionality - not guaranteed:
 - “versions” of HTML poorly controlled
 - layout not constrained by HTML
 - availability of proprietary extensions (plug-ins, applets)
 - e.g., “this page only for IE version 5.0”
- Good, but not good enough for healthcare

DICOM and *Inter-operability*

- For example, conformance to DICOM
 - will guarantee network connection
 - will guarantee storage of MR image:
 - from Modality to Workstation
 - will NOT guarantee (but will facilitate):
 - workstation will display image “correctly”
 - workstation can perform the analysis the user wants
 - facilitated by mandatory attributes for:
 - identification, annotation, positioning, etc.
 - *newer DICOM objects increase what is mandatory*

Greater Inter-functionality

- Cardiac motion - vendor independent applications that handle spatial and temporal (cardiac cycle) CT and MR images
- Diffusion MR - vendor independent applications that handle diffusion B value and direction
- Multi-stack spine - vendor independent applications that recognize stacks of parallel slices through inter-vertebral disk spaces
- Contrast and perfusion - vendor independent applications that recognize timing and phase of enhancement in CT and MR images for display and or quantitative analysis
- Spectroscopy - vendor independent applications that process and display single-voxel, multi-voxel or multi-slice MR spectra and reference and metabolite map images

Enhanced DICOM Images

- Enhanced MR Image - Sup 49 (standard)
- Enhanced CT Image - Sup 58 (standard)
- Enhanced XA/XRF - Sup 83 (standard)
- Enhanced PET - Sup 117 (work in progress)
- 3D X-ray - Sup 116 (work in progress)
- Enhanced US - Sup 43 (work in progress)

Multi-frame Organization of New CT & MR Images

- Original objects
 - Series organization + single frame + a few attributes + terms
- Enhanced objects
 - Multiple frames in a single object
 - Many more standard mandatory attributes
 - Many more standard terms
- Enables
 - Greater interfunctionality of applications
 - More effective hanging protocols
 - Reduced dependence on private attributes

Technique Attributes & Terms

	CT		MR	
SOP Class	Original	Enhanced	Original	Enhanced
Attributes (Mandatory)	18 (0)	41 (39)	44 (2)	103 (94)
Terms (Enumerated)	4 (2)	86 (18)	38 (9)	228 (47)

CT Image Type Value 3

- Original SOP Classes
 - AXIAL or LOCALIZER
- Enhanced SOP Classes
 - Common to CT and MR
 - ANGIO, FLUOROSCOPY, LOCALIZER, MOTION, PERFUSION, PRE_CONTRAST, POST_CONTRAST, REST, STRESS, VOLUME
 - CT-specific
 - ATTENUATION, CARDIAC, CARDIAC_GATED, REFERENCE

MR Acquisition Contrast

- Original SOP Classes
 - Guess from echo and repetition time, etc.
- Enhanced SOP Classes
 - New mandatory frame level attribute
 - Acquisition Contrast
 - DIFFUSION, FLOW_ENCODED, FLUID_ATTENUATED, PERFUSION, PROTON_DENSITY, STIR, TAGGING, T1, T2, T2_STAR, TOF, UNKNOWN

Geometry unchanged

- Same as original SOP Classes
- Image Position and Orientation (Patient)
- Still need to compute AXIAL, SAGITTAL or CORONAL from orientation vector
- Still need to compute edge labels (A/P etc) from orientation vector
- May still need to compare orientation vectors to determine if slices are parallel - stacks will be discussed later

Enhanced Contrast/Bolus

- Original SOP Classes
 - Plain text description
 - Difficult to determine presence/absence
 - E.g., description value of “None”
 - Single agent (did not distinguish oral/iv)
 - Codes optional and never used
- Enhanced SOP Classes
 - Mandatory codes only
 - Multiple items with separate coded routes & timing
 - Presence or absence per-frame can be described

Coded anatomic regions

- Original SOP Classes
 - Incomplete list of optional defined terms
 - Optional laterality
- Enhanced SOP Classes
 - Mandatory coded anatomic region
 - Comprehensive & appropriate list of codes
 - Mandatory laterality
 - Per-frame or for entire object
- E.g.
 - (R-FAB56,SRT,“Chest, Abdomen and Pelvis”)
 - Not free text “C/A/P” or “CAP.” or “Chest, abdo, pelvis” etc.

Hanging protocol rule impact

T1 SAG
PRE GD

T1 AXIAL
PRE GD

T2 AXIAL

T1 AXIAL
POST GD

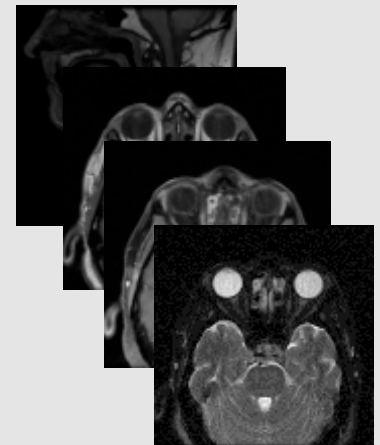

Hanging protocol rule impact

T1 SAG
PRE GD

T1 AXIAL
PRE GD

T2 AXIAL

T1 AXIAL
POST GD

Acquisition Contrast = T1

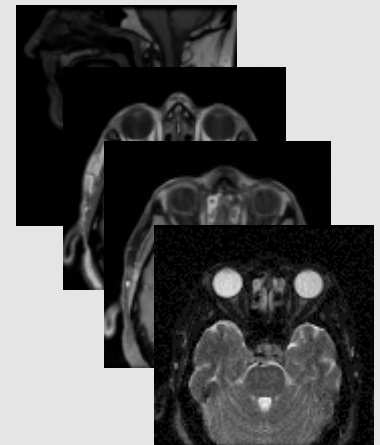

Hanging protocol rule impact

T1 SAG
PRE GD

T1 AXIAL
PRE GD

T2 AXIAL

T1 AXIAL
POST GD

Acquisition Contrast = T1

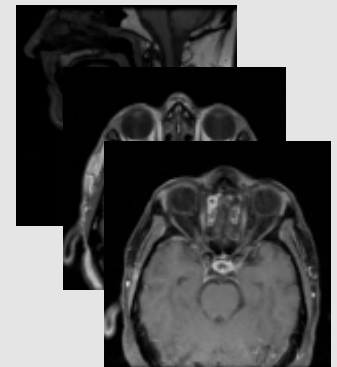

Hanging protocol rule impact

T1 SAG
PRE GD

T1 AXIAL
PRE GD

T2 AXIAL

T1 AXIAL
POST GD

Acquisition Contrast = T1
Image Orientation $\approx 0\ 1\ 0\ 0\ 0\ -1$

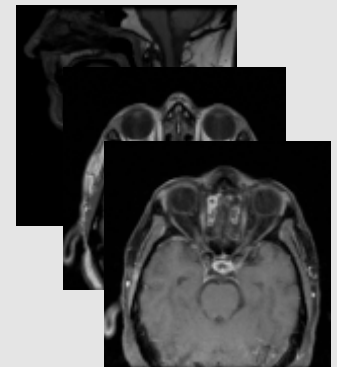

Hanging protocol rule impact

T1 SAG
PRE GD

T1 AXIAL
PRE GD

T2 AXIAL

T1 AXIAL
POST GD

Acquisition Contrast = T1
Image Orientation $\approx 0\ 1\ 0\ 0\ 0\ -1$

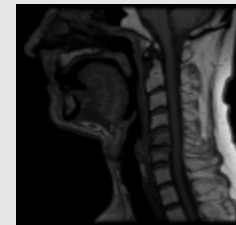

Hanging protocol rule impact

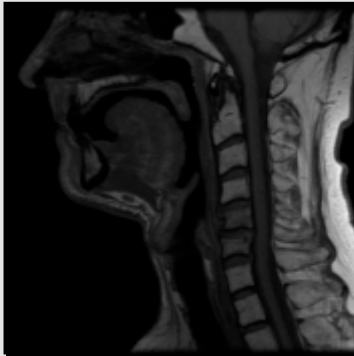

T1 AXIAL
PRE GD

T2 AXIAL

T1 AXIAL
POST GD

Acquisition Contrast = T1
Image Orientation \approx 0\1\0\0\0\0\0\0\0\1

Contrast Agent #1

Administered = NO

Route = (G-D101,SNM3, "IV")

Ingredient = (C-17800,SRT, "Gd")

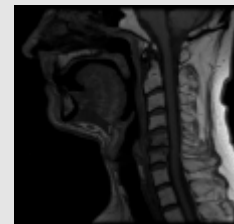

Hanging protocol rule impact

T1 SAG
PRE GD

T1 AXIAL
PRE GD

T2 AXIAL

T1 AXIAL
POST GD

Acquisition Contrast = T1

Image Orientation \approx 1\0\0\0\1\0

Contrast Agent #1

Administered = NO

Route = (G-D101,SNM3, "IV")

Ingredient = (C-17800,SRT, "Gd")

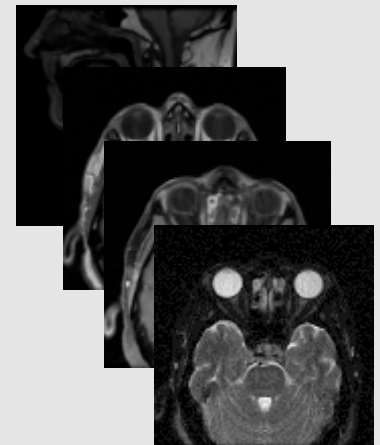

Hanging protocol rule impact

T1 SAG
PRE GD

T1 AXIAL
PRE GD

T2 AXIAL

T1 AXIAL
POST GD

Acquisition Contrast = T1

Image Orientation \approx 1\0\0\0\1\0

Contrast Agent #1

Administered = NO

Route = (G-D101,SNM3, "IV")

Ingredient = (C-17800,SRT, "Gd")



Hanging protocol rule impact

T1 SAG
PRE GD

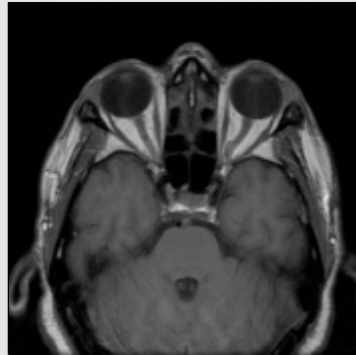

T2 AXIAL

T1 AXIAL
POST GD

Acquisition Contrast = T1

Image Orientation \approx 1\0\0\0\1\0

Contrast Agent #1

Administered = NO

Route = (G-D101,SNM3, "IV")

Ingredient = (C-17800,SRT, "Gd")



Hanging protocol rule impact

T1 SAG
PRE GD

T1 AXIAL
PRE GD

T2 AXIAL

T1 AXIAL
POST GD

Acquisition Contrast = T2

Image Orientation \approx 1\0\0\0\1\0

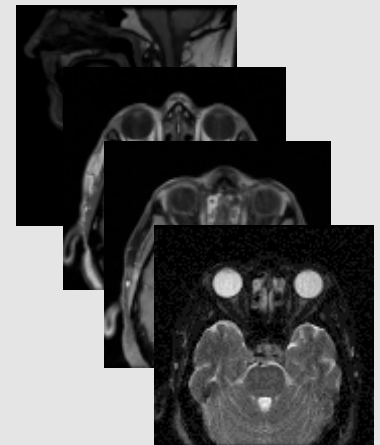

Hanging protocol rule impact

T1 SAG
PRE GD

T1 AXIAL
PRE GD

T2 AXIAL

T1 AXIAL
POST GD

Acquisition Contrast = T2

Image Orientation \approx 1\0\0\0\1\0

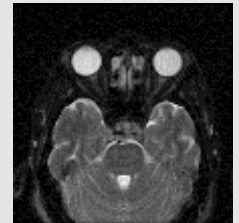

Hangings protocol rule impact

T1 SAG
PRE GD

T1 AXIAL
PRE GD

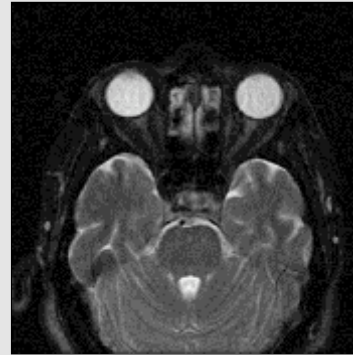

T1 AXIAL
POST GD

Acquisition Contrast = T2
Image Orientation \approx 1\0\0\0\1\0

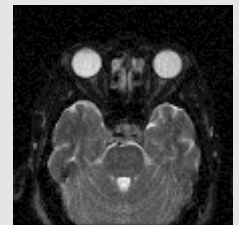

Hanging protocol rule impact

T1 SAG
PRE GD

T1 AXIAL
PRE GD

T2 AXIAL

T1 AXIAL
POST GD

Acquisition Contrast = T1

Image Orientation \approx 1\0\0\0\1\0

Contrast Agent #1

Administered = YES

Route = (G-D101,SNM3, "IV")

Ingredient = (C-17800,SRT, "Gd")

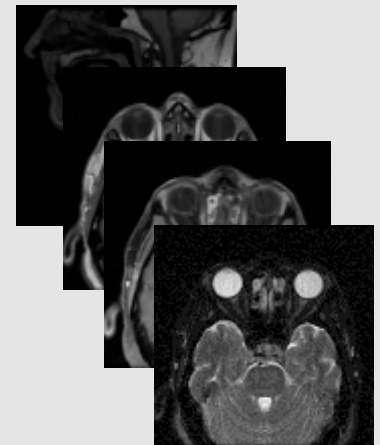

Hanging protocol rule impact

T1 SAG
PRE GD

T1 AXIAL
PRE GD

T2 AXIAL

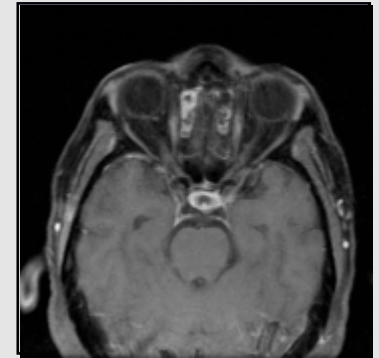

Acquisition Contrast = T1

Image Orientation \approx 1\0\0\0\1\0

Contrast Agent #1

Administered = YES

Route = (G-D101,SNM3, "IV")

Ingredient = (C-17800,SRT, "Gd")

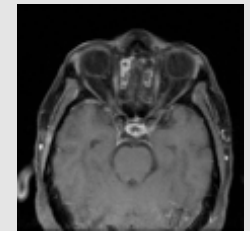

Hangin protocol rule impact

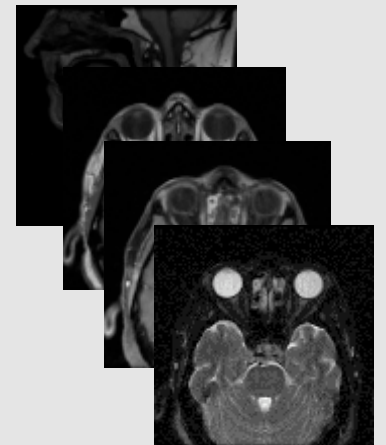
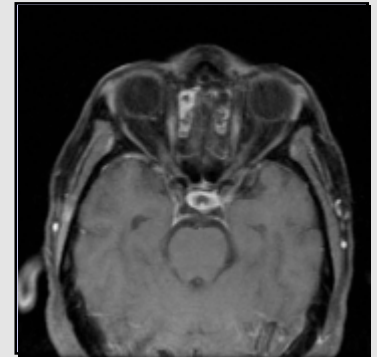
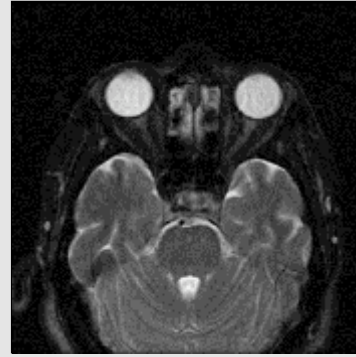
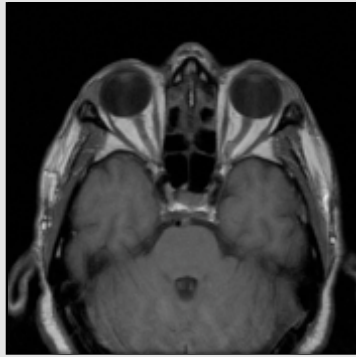
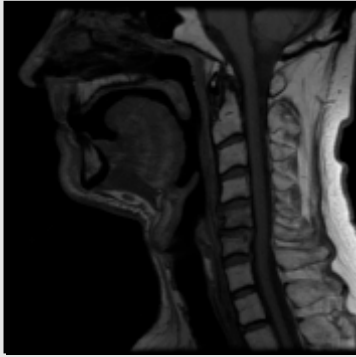

Hanging protocol rule impact

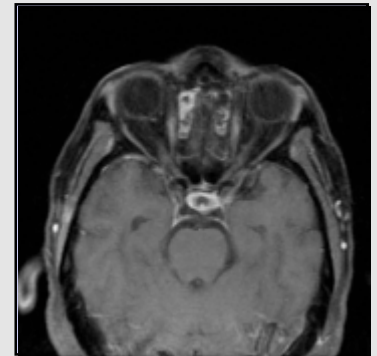
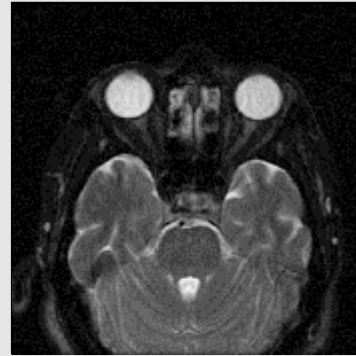
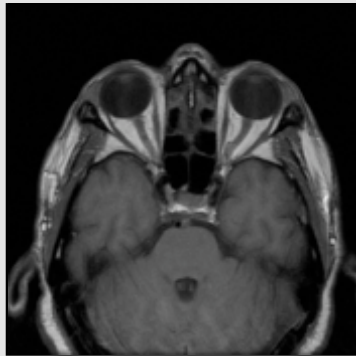
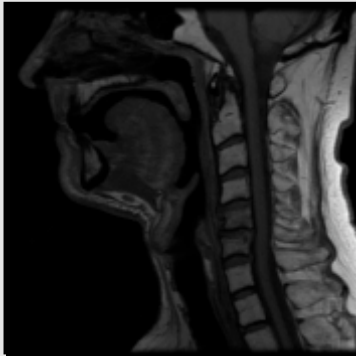

Same rules, independent of whether:

- one single multi-frame image
- one multi-frame image per acquisition
- one slice per single frame image
- one series or multiple

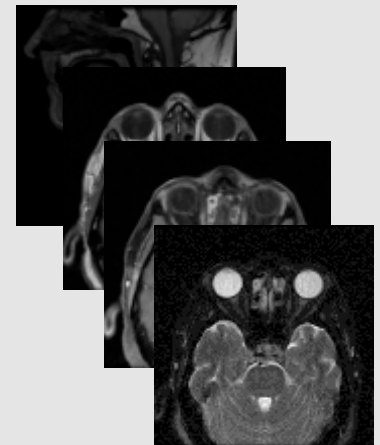

Hanging protocol support

- A productivity advantage of the CT and MR objects
- Should not have to tailor hanging protocol rules to specific vendors or devices or versions
- Reliable and standard information
 - Mandatory and standard places (attributes)
 - Mandatory and standard values
- As technology evolves, yet more standard values will be added to the standard
- Eliminate dependence on site configured Series Number or Series Description, whether from acquisition protocol or entered by operator

DICOM Hanging Protocols

- Foregoing describes how to use attributes in Enhanced CT and MR objects to improve any hanging protocol engine, including proprietary software
- DICOM also has recently defined Hanging Protocol SOP Classes
- To store hanging protocol rules centrally and exchange them between different systems
- Not a pre-requisite for making use of the enhanced image objects to improve hanging

Beyond simple image display

- Visualization
- Temporal change
 - Short term
 - Long term
- Quantitation and Analysis

Visualization

- MPR
- 3D surface and volume rendering
- MIP for angiography
- Fusion

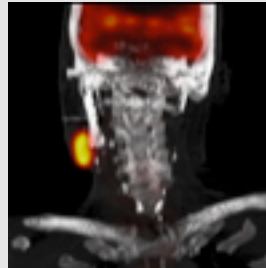
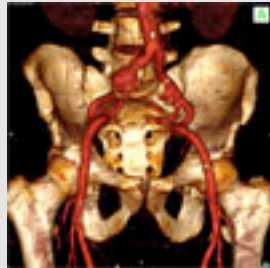
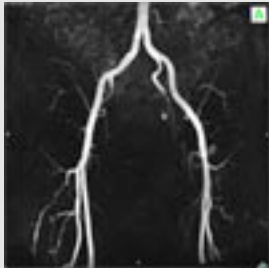

Temporal change

- Short term
 - Perfusion
 - Cardiac cycle
- Long term
 - Change over time between studies



Quantitation and analysis

- Processing of multiple frames
- Measurement of morphology
 - Linear distance
 - Volumetrics
- Measurement of physiology and function
 - Perfusion and diffusion
 - fMRI
- Registration
 - between acquisitions, studies & modalities

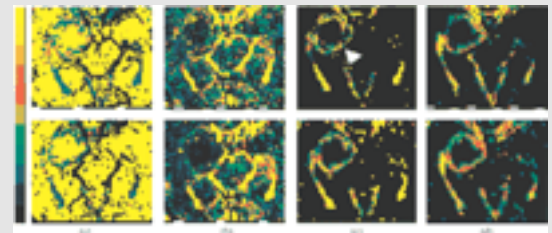
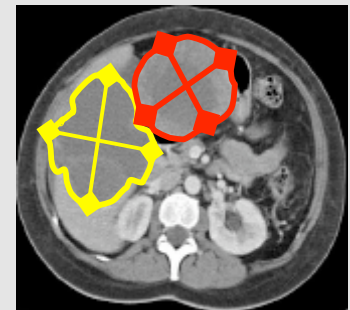

Jackson, 2003, BJR

Supporting advanced applications

- Original SOP Classes
 - Minimal standard acquisition information
 - Imprecisely defined timing information
 - No organizational structures except Series
 - Quantitation mixed with grayscale pipeline
- Enhanced SOP Classes
 - Detailed descriptions of advanced acquisition protocols
 - Accurate and well-defined timing information
 - Pre-defined organizational structures
 - Quantitative values and color support

Enhanced MR attribute types

- Separate gradient and RF echo train lengths
- Out-of-plane phase encoding steps
- Flow compensation
- Spectrally selective excitation & suppression
- Blood signal nulling
- Tagging
- Diffusion values and direction
- Spatial saturation slabs
- Velocity encoding
- Chemical shift imaging (metabolite maps)

Enhanced CT attribute types

- Acquisition type
- Constant volume and fluoroscopy
- Single and total collimation width (for multiple detectors)
- Table speed, feed and spiral pitch factor
- Reconstruction geometry and convolution kernel
- Exposure information, dose savings and $CTDI_{Vol}$

Timing information

- Original SOP Classes
 - Inconsistent use of Content (Image) and Acquisition Time
 - Contrast timing information never used
- Enhanced SOP Classes
 - Unambiguous definition of acquisition timing
 - Explicit relationships with contrast & cardiac timing

Timing information

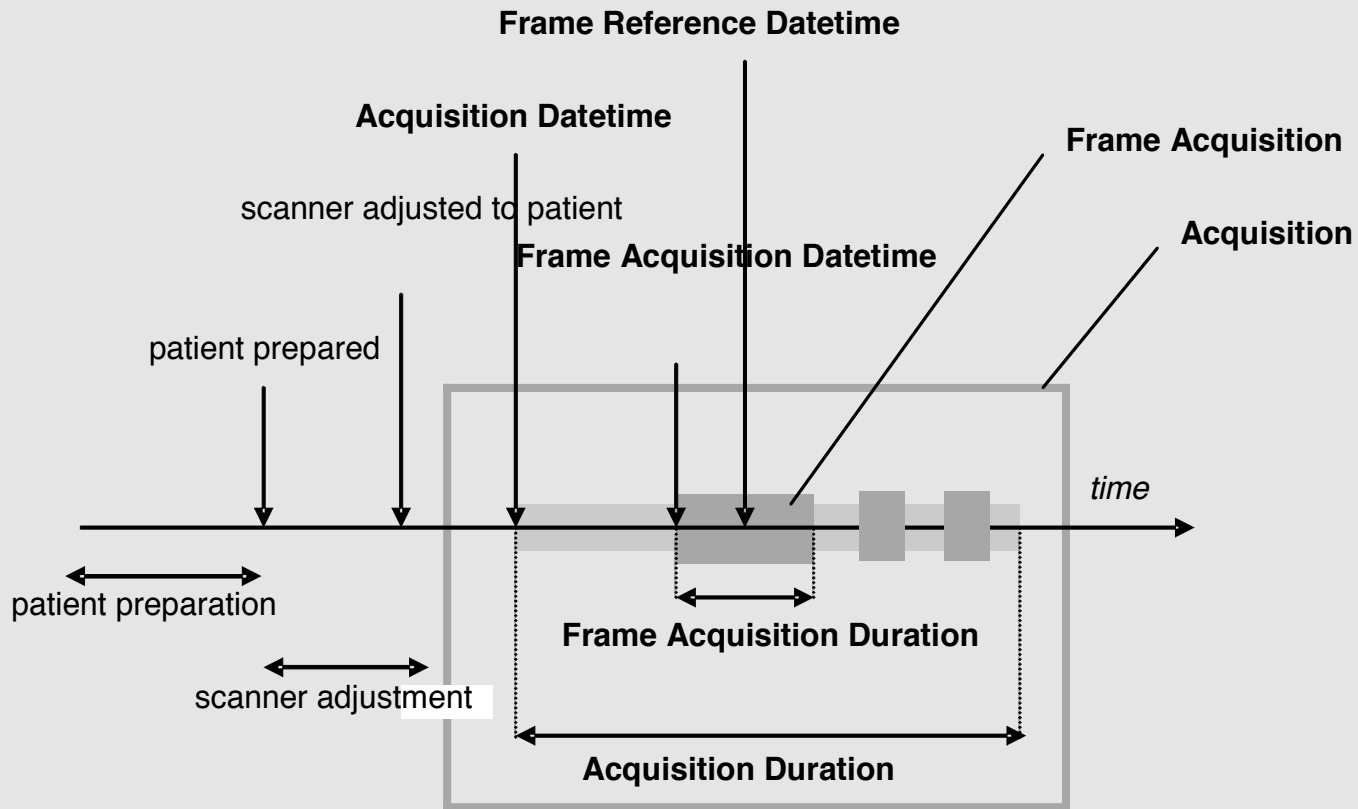

Timing information

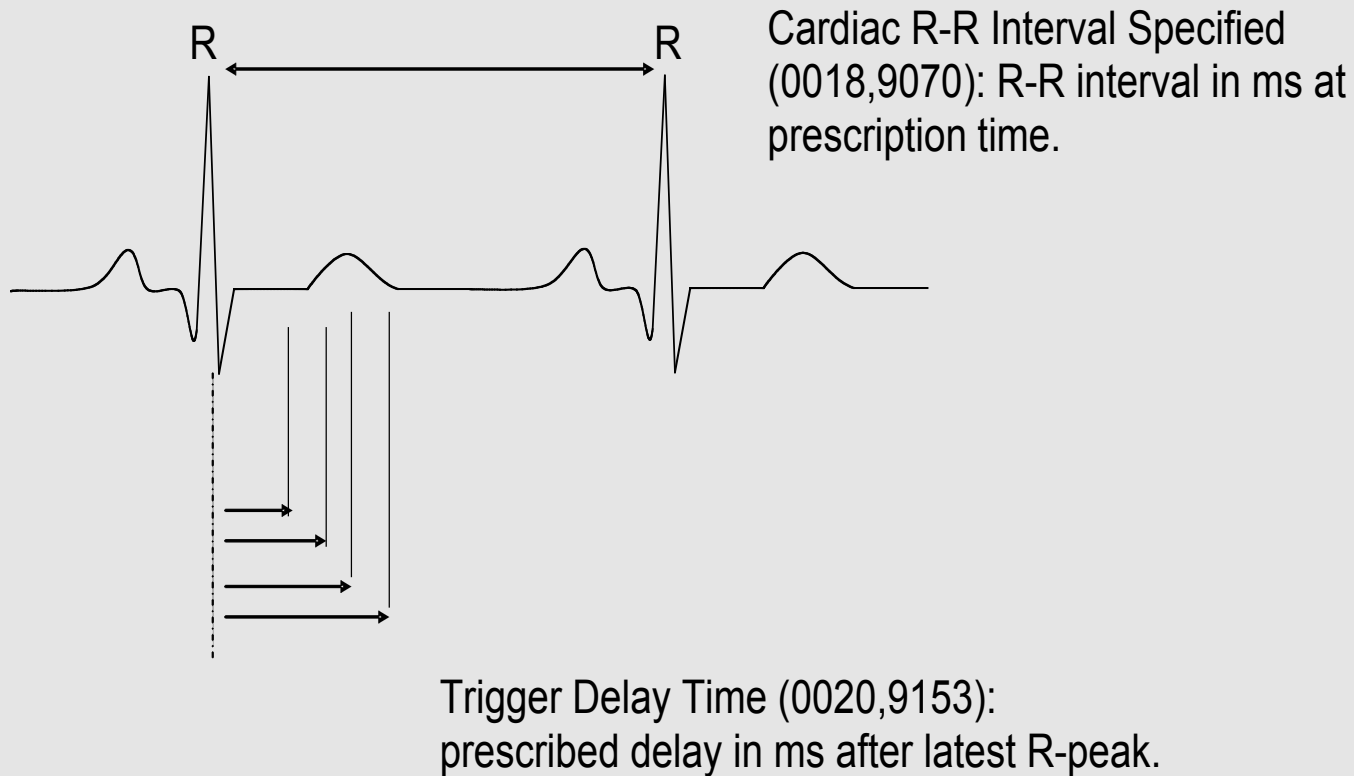

Contrast timing

- Numeric - Administration Profile
 - Allows for multiple contrast agents and phases
 - Volume, start/stop times, rates and duration
- Categorical
 - Can be specified on a per-frame basis
 - Administered - YES/NO
 - Detected - YES/NO
 - Phase - PRE_CONTRAST, POST_CONTRAST, IMMEDIATE, DYNAMIC, STEADY_STATE, DELAYED, ARTERIAL, CAPILLARY, VENOUS, PORTAL_VENOUS

Contrast timing - phase for hanging protocols

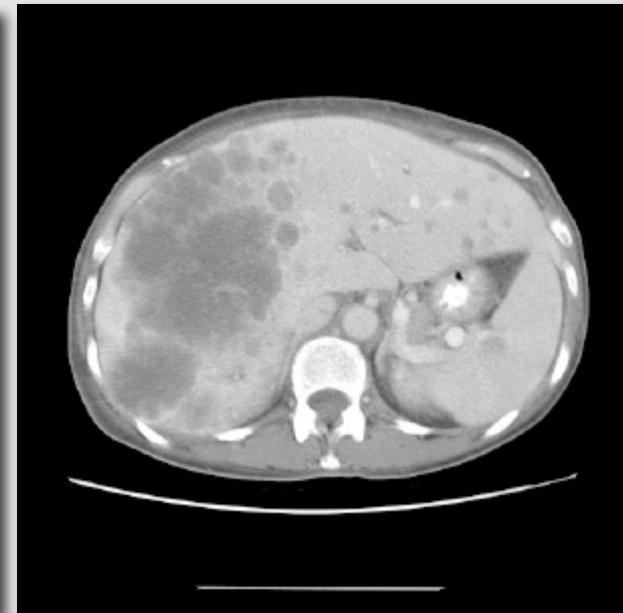
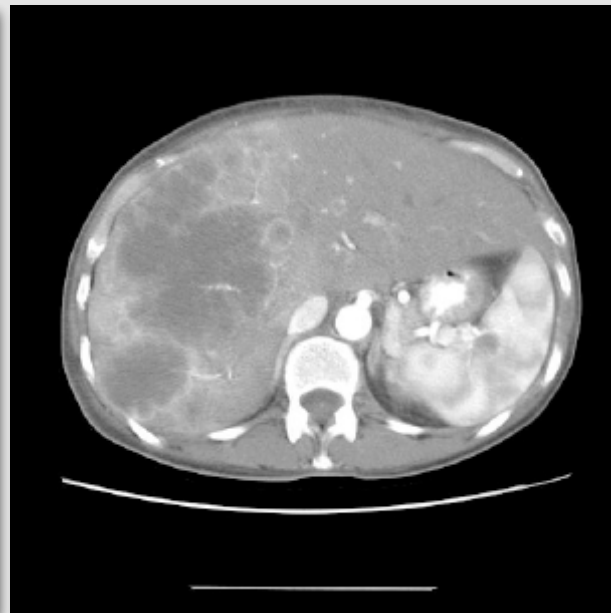

Organizational Features

- Multi-frame pixel data
- Shared and per-frame functional groups
 - Each functional group contains attributes that likely vary as a group, e.g. Pixel Measures, Plane Orientation, Velocity Encoding, etc.
 - Compact & makes explicit what doesn't change
- Dimensions
 - *a priori* hints as to how the frames are organized
 - Specify intended order of traversal, such as space, then time (e.g., for cardiac cine loops)
- Stacks
 - Groups of spatially-related slices, repeatable
- Temporal positions

Organization of Data

- Goal is to reduce the work that the receiving application has to do to “figure out”
 - How the data is organized
 - Why it is organized that way
- Without preventing use of the data in unanticipated ways
 - E.g. 3D on a dataset not intended as a volume
- Two levels
 - The detailed shared & per-frame attributes
 - The overall dimensions, stacks and temporal positions

Multi-frame Functional Groups

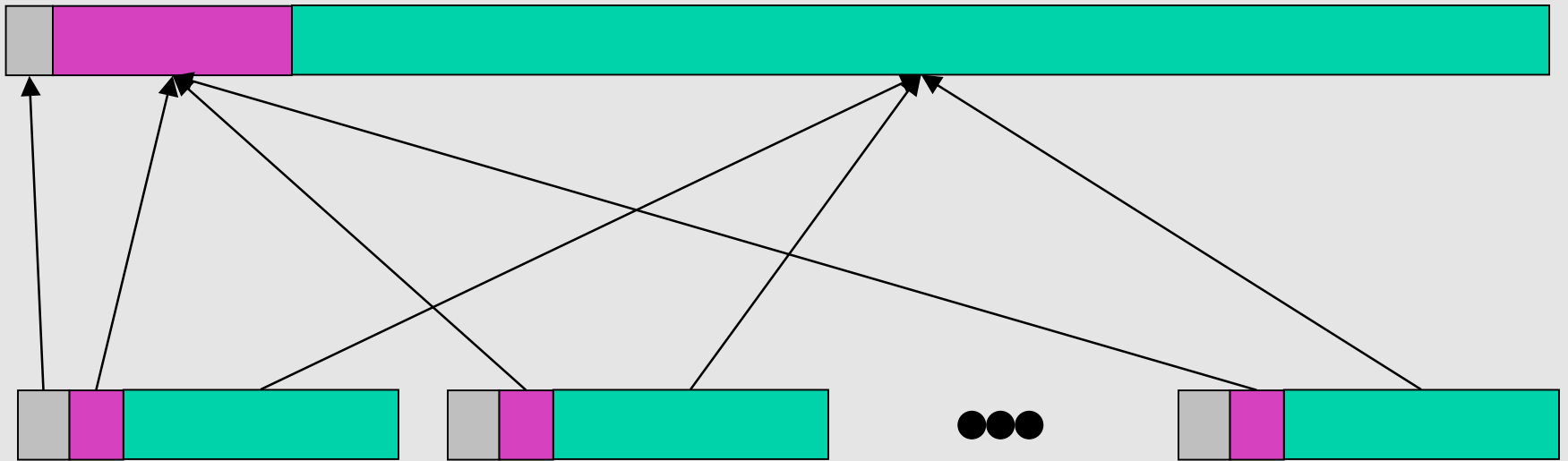

Shared attributes



Per-frame attributes



Pixel data

Stacks

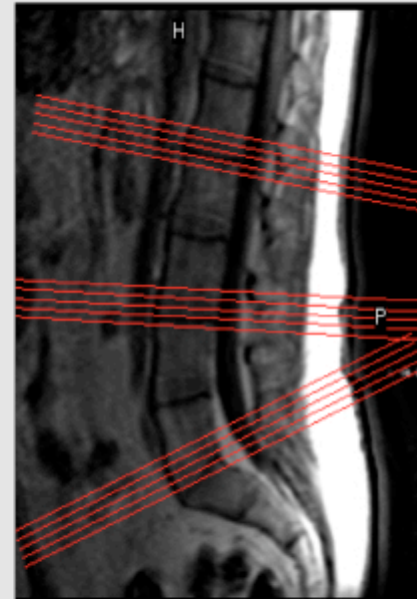
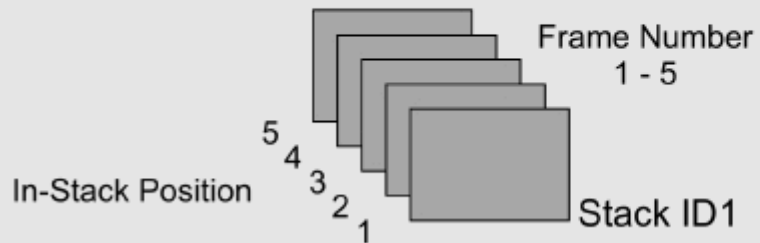
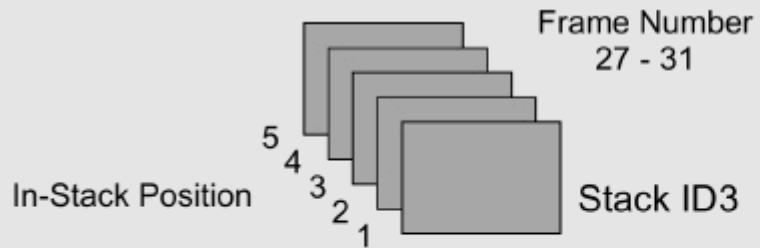

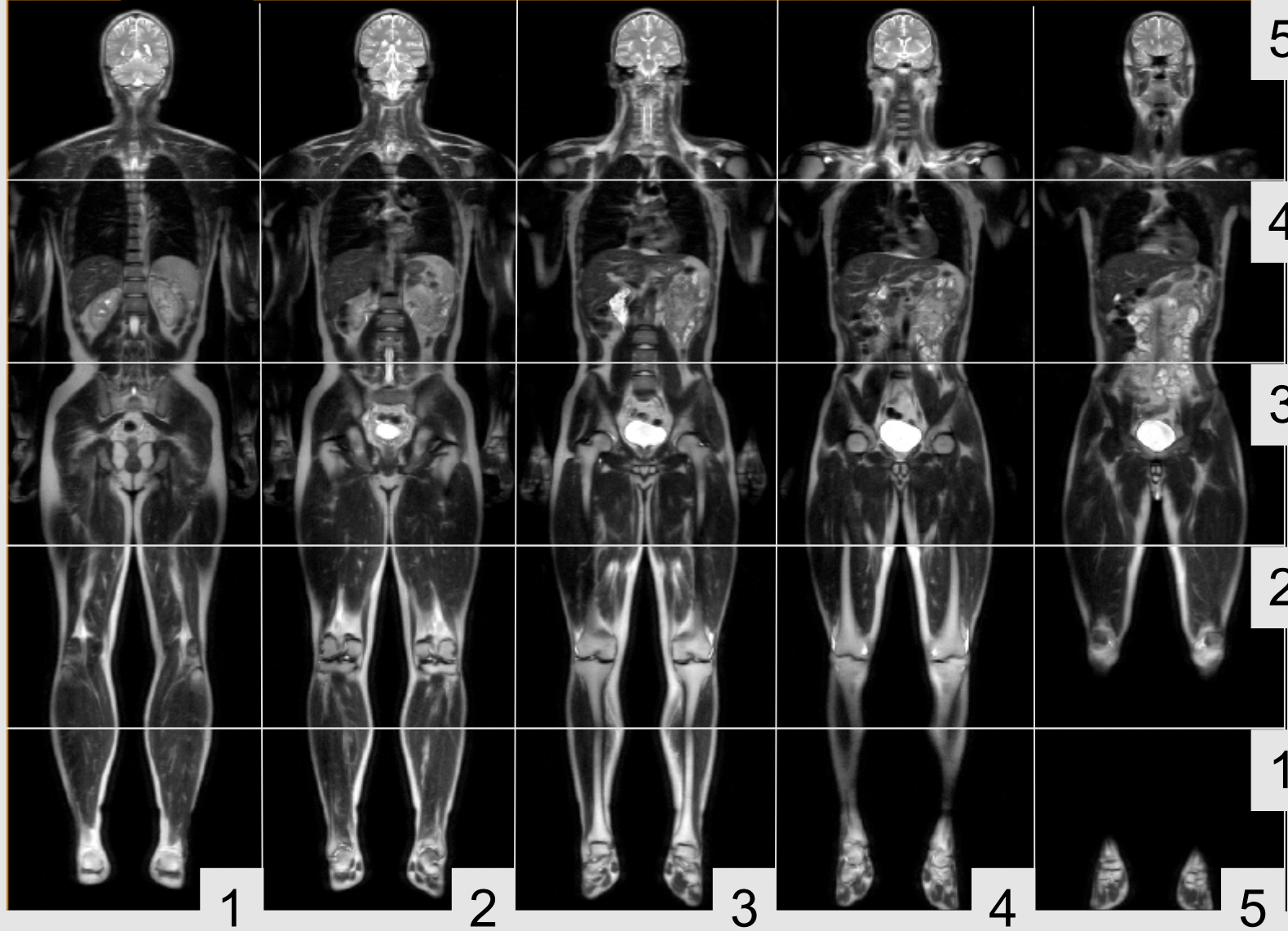

Stack ID



In-Stack Position 

Dimensions

Start with a dimension of space.

A set of contiguous slices through the heart.

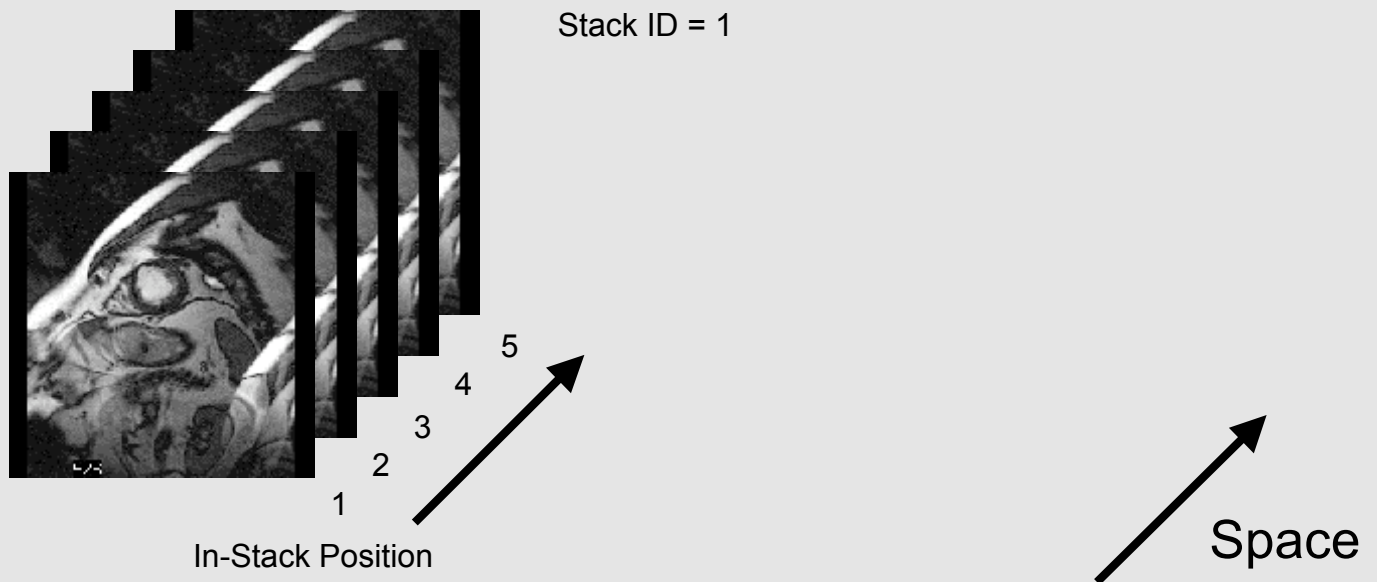

Trigger
Delay
Time

Temporal
Position
Index

48 ms

2

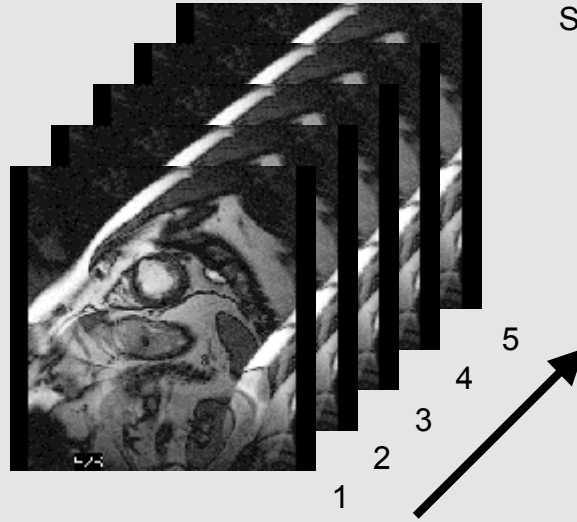

Stack ID = 1

In-Stack Position

Add dimension of time
(delay time from R-wave).

Sets of contiguous slices
throughout cardiac cycle.

0 ms

1

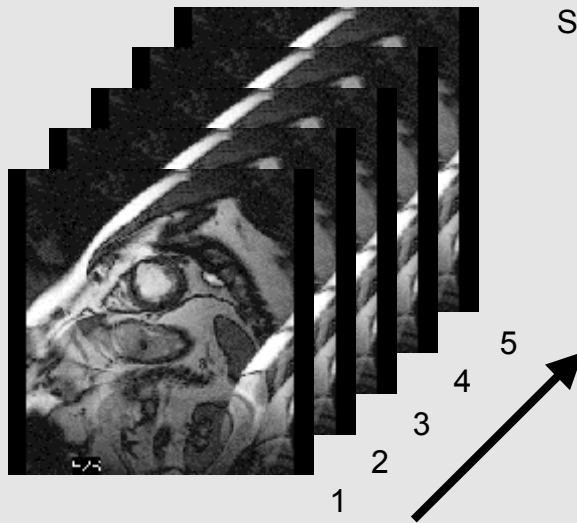

Stack ID = 1

In-Stack Position

Time



Space



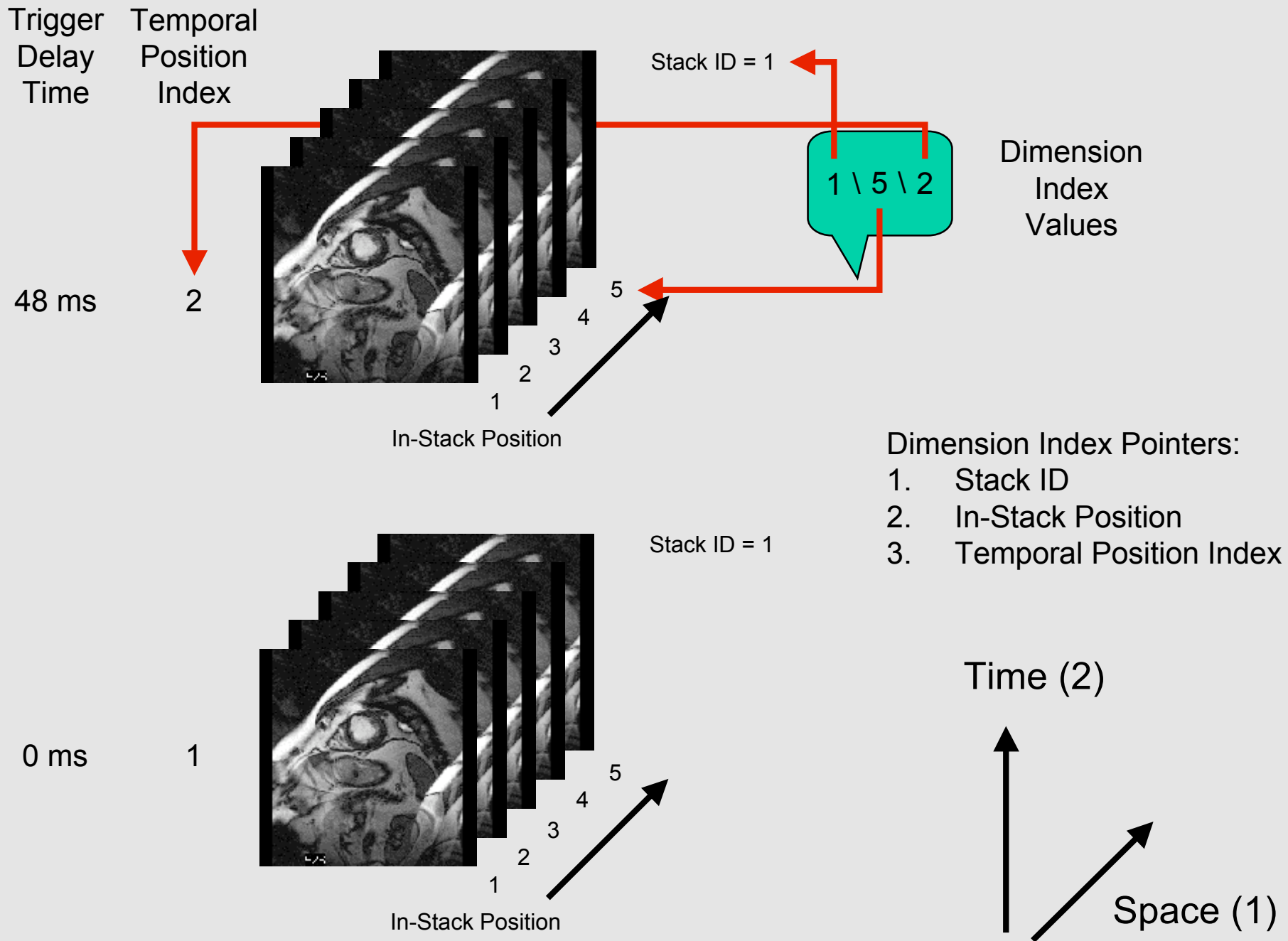

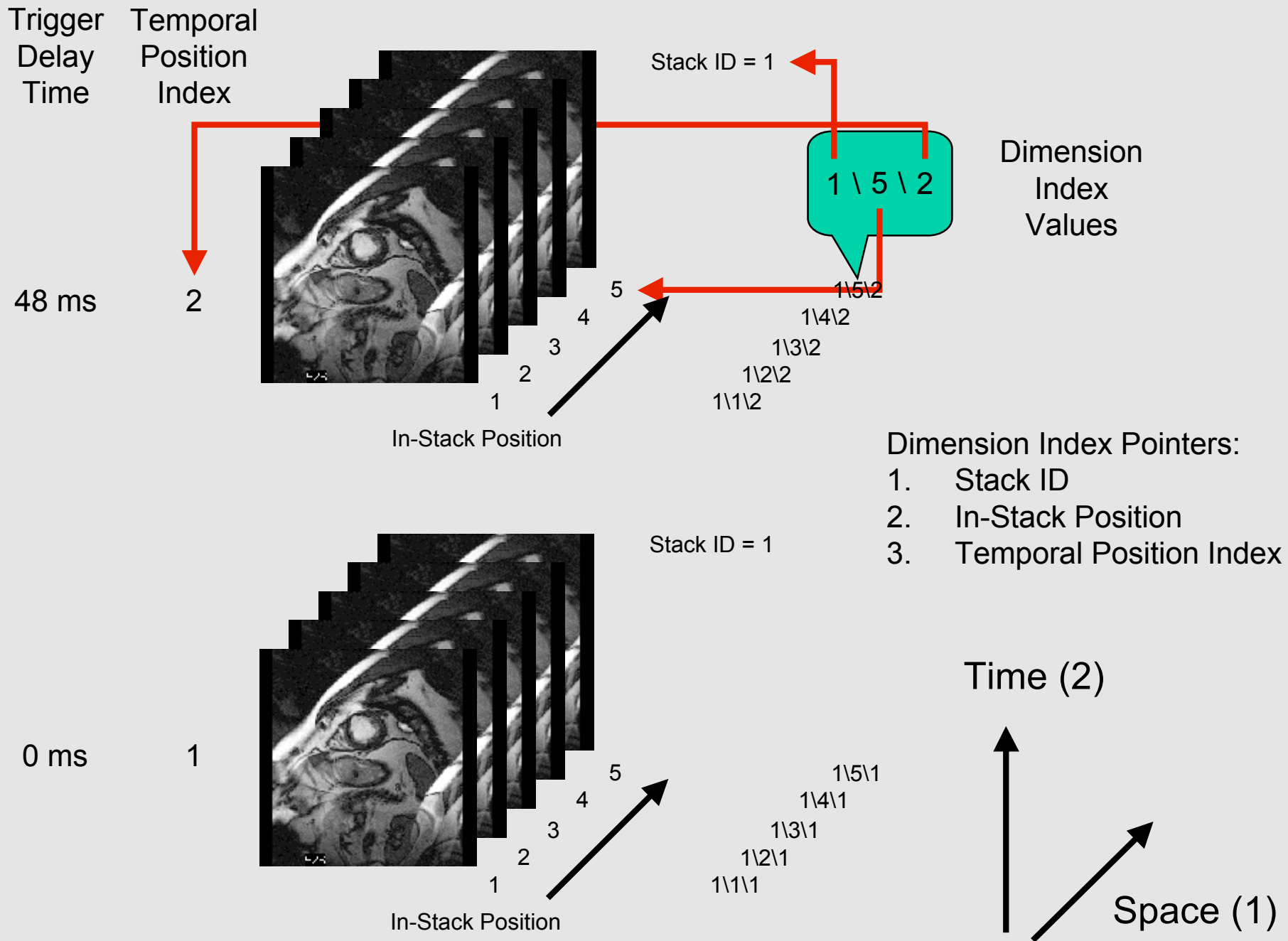

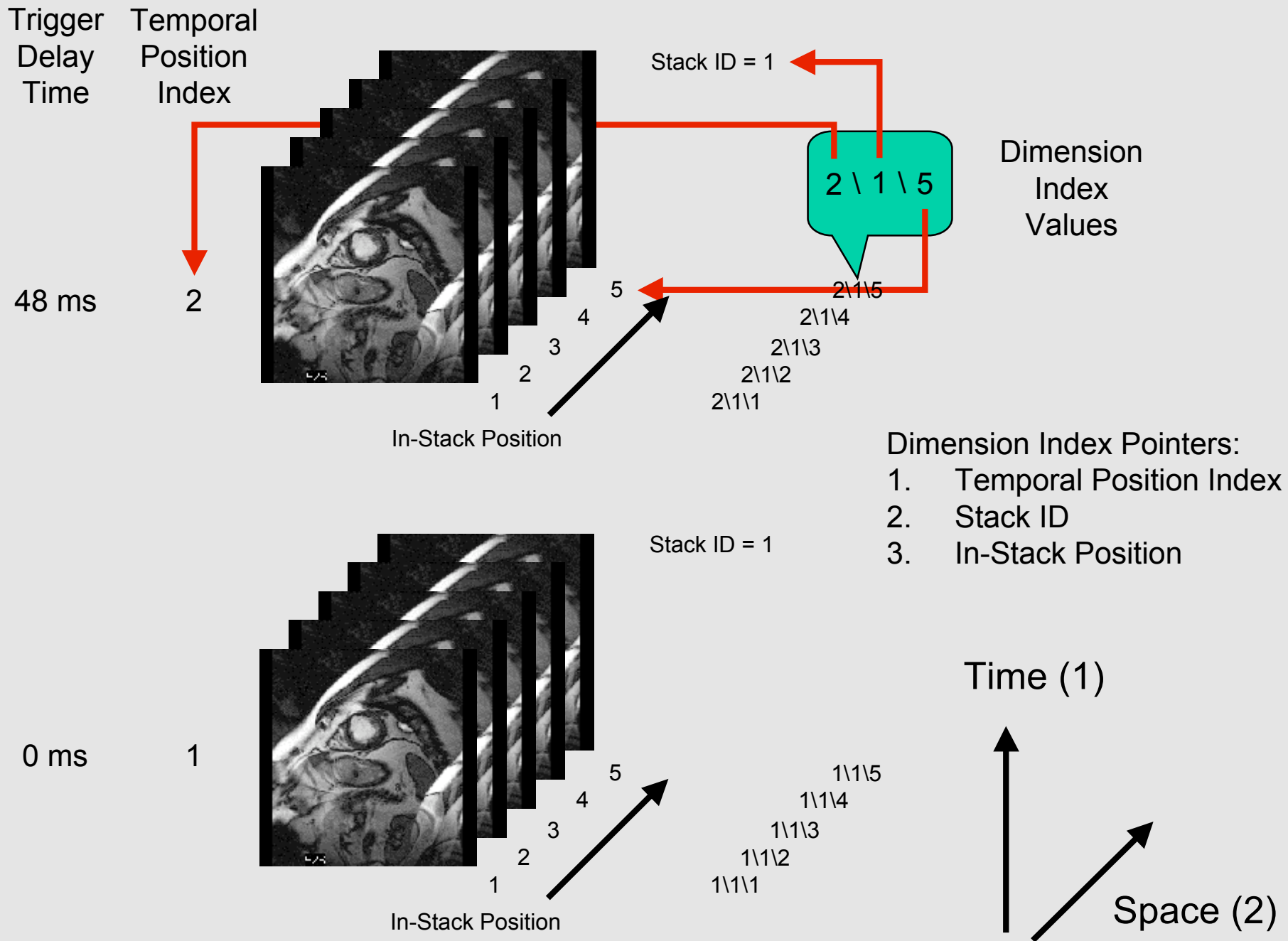

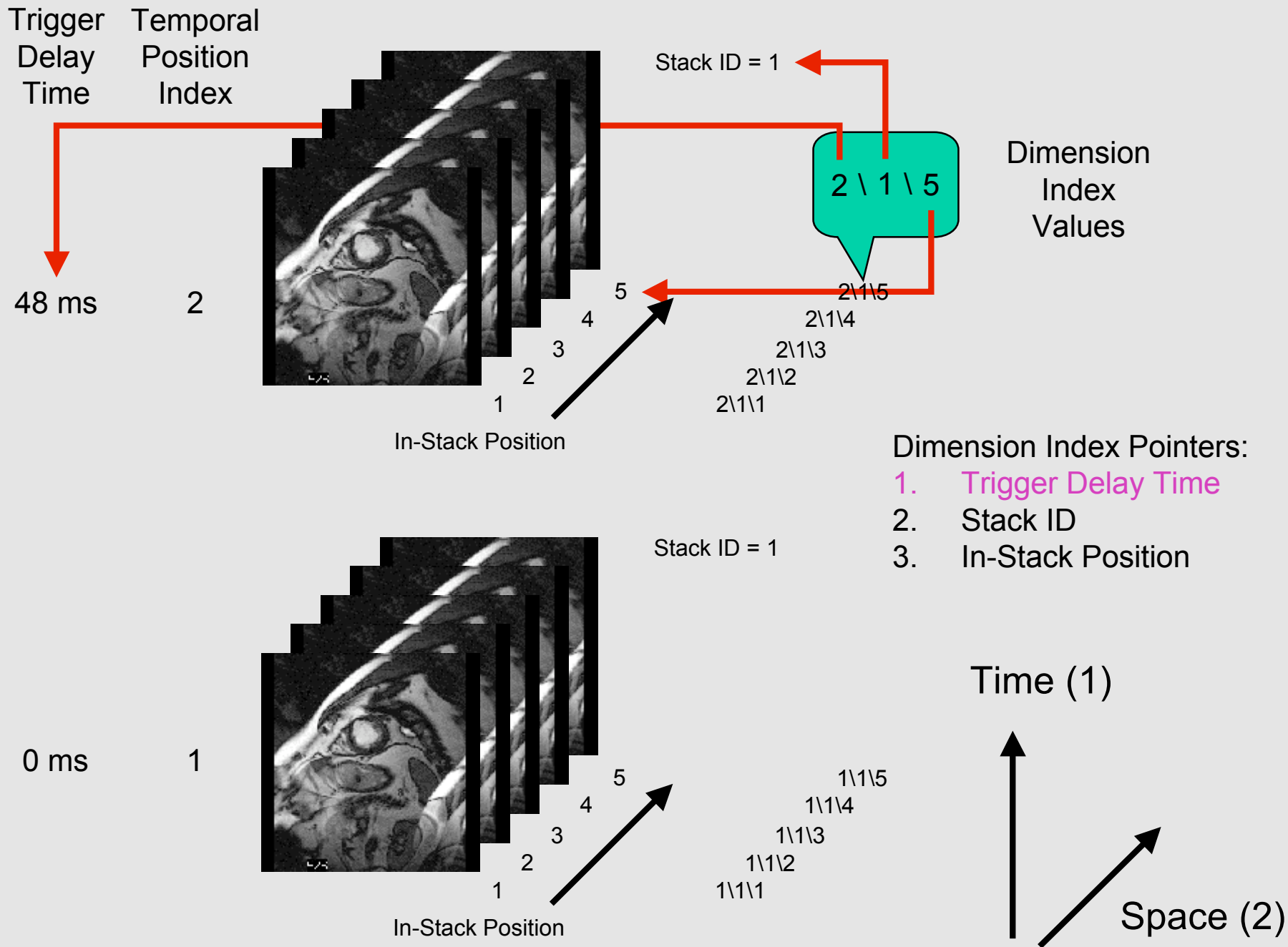

Dimension features

- Description of dimensions separate from their indices
 - Dimensions are described once
 - Indices within dimensions are encoded per-frame
- Receiving application only needs to follow the index values
 - Does NOT need to select or sort by attribute value
 - Dimensions can be entire functional groups
 - Dimensions can be private attributes or functional groups

Dimension applications

- Selection of sort order for simple viewing
- Partitioning of frames for hanging
- Selection of frames that constitute a
 - volume in space
 - temporal sequence
 - contrast administration phase
 - physiological parameter, e.g. diffusion b value

Quantitation of pixel values - Real World Values

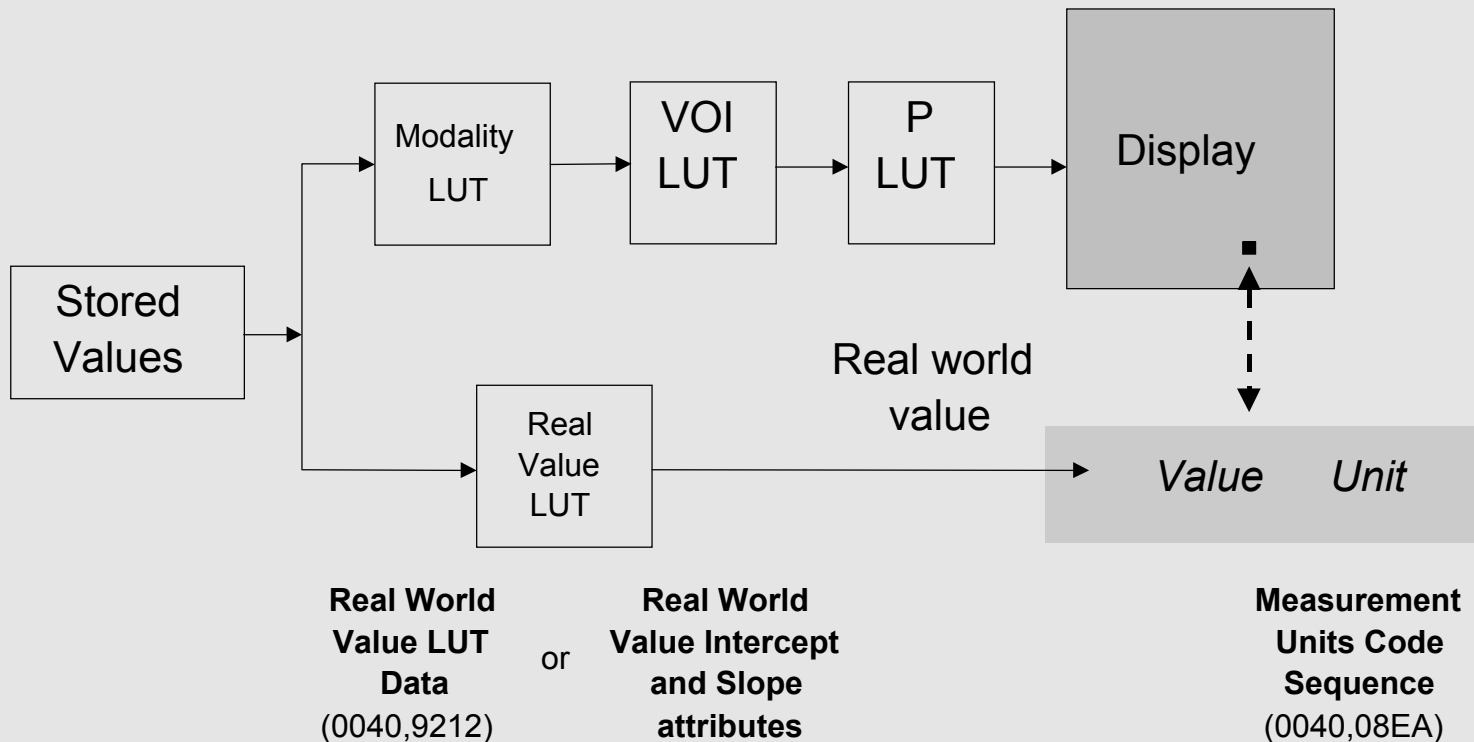

Real World Values

- Separate from grayscale pipeline
- May be non-linear
- May be multiple mappings into different units

Color display of functional data

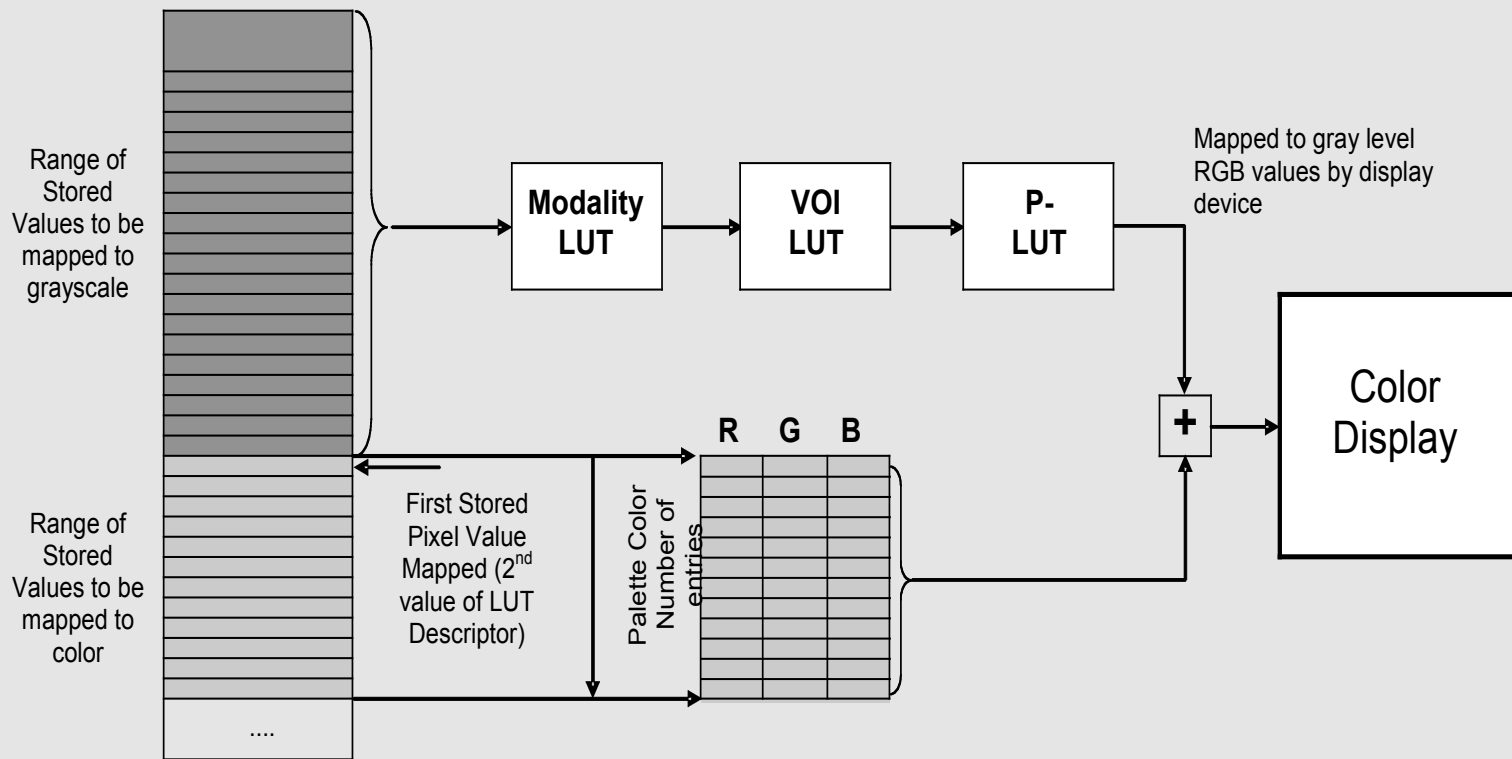

Color by functional paradigm

Pixel Values

Anatomic
Reference

VOI
LUT

Grayscale
Window/Level

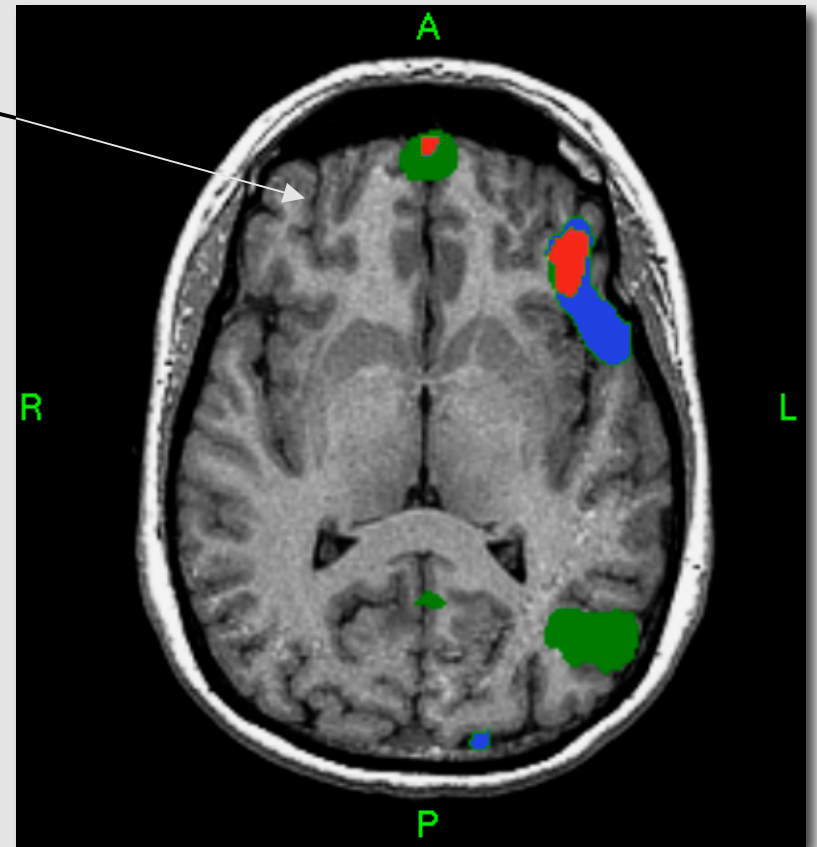

Color by functional paradigm

Pixel Values

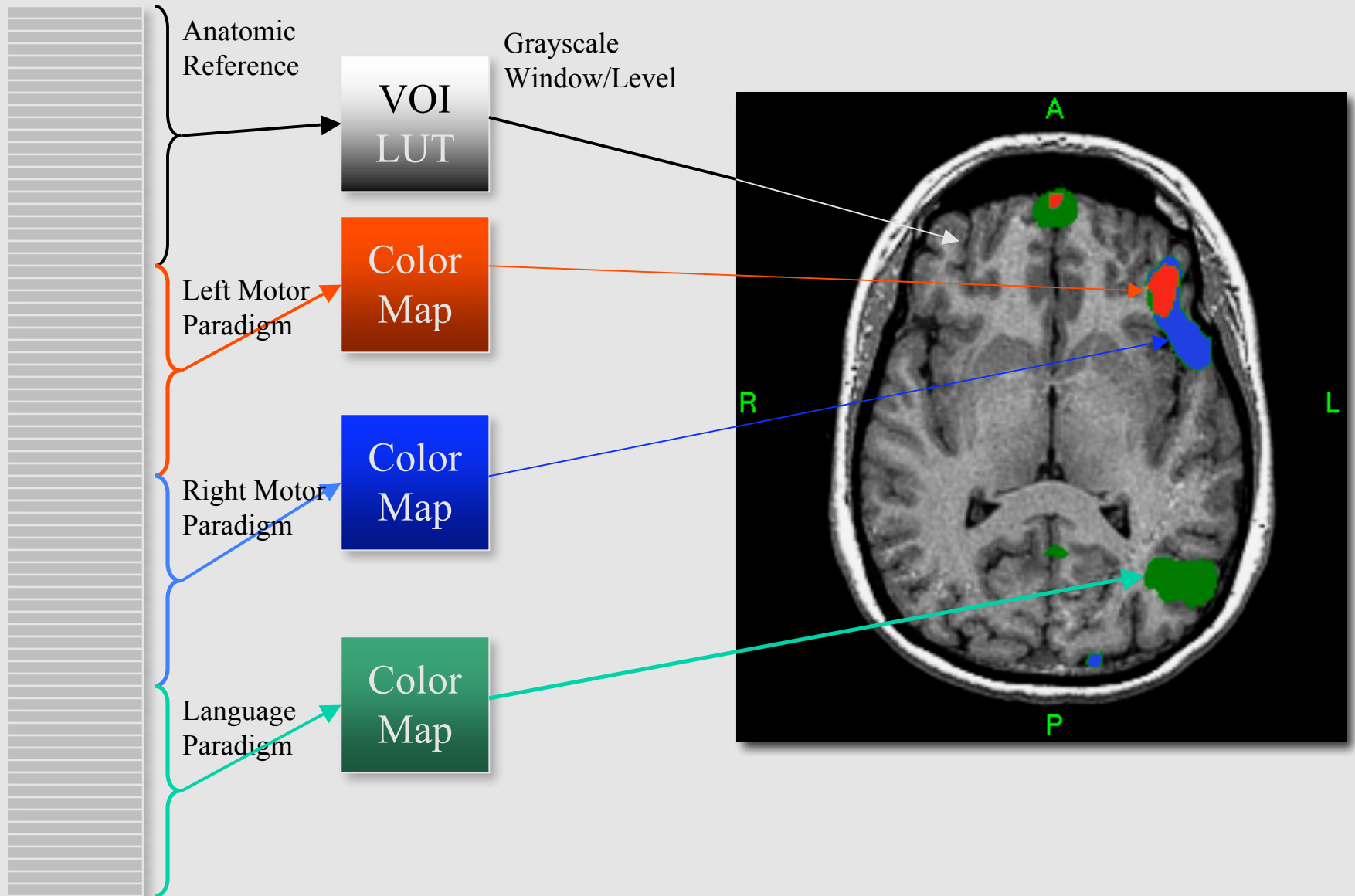

Color by functional paradigm

Pixel Values

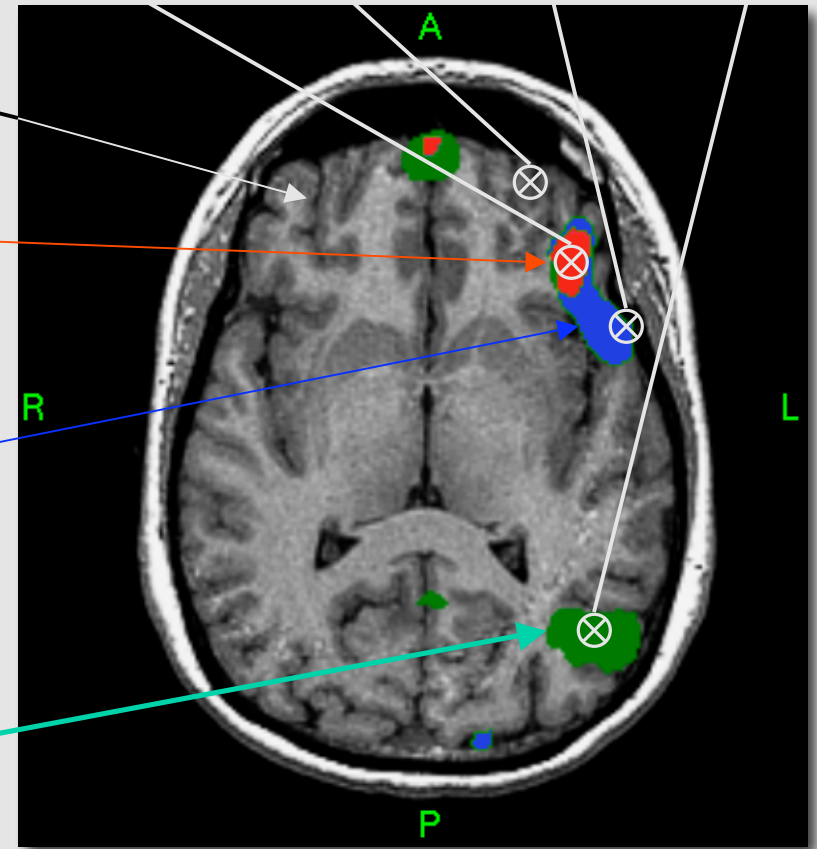
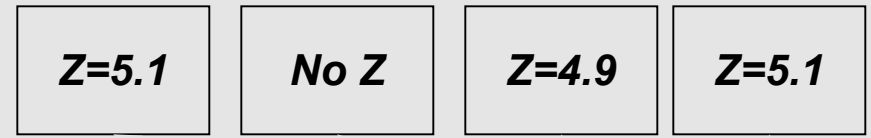
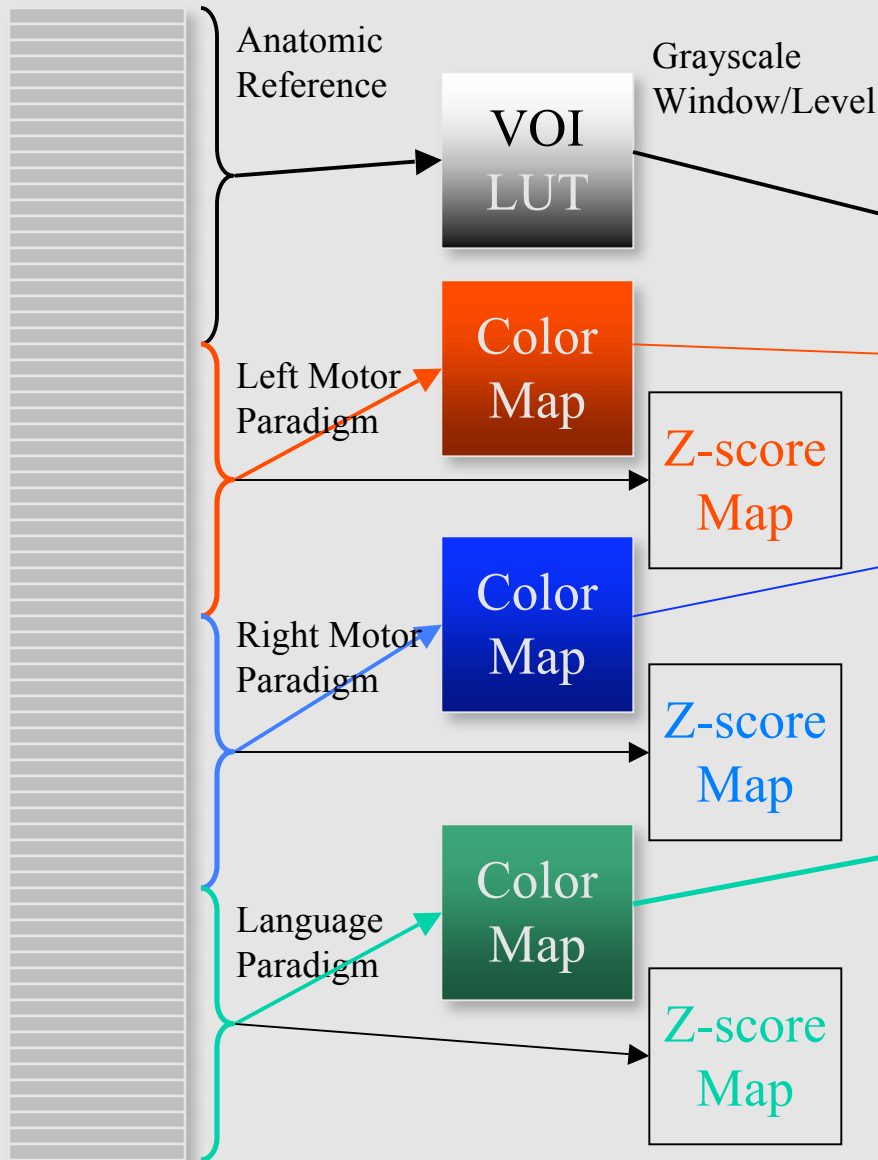

Z Score Real World Value Map

Color information applications

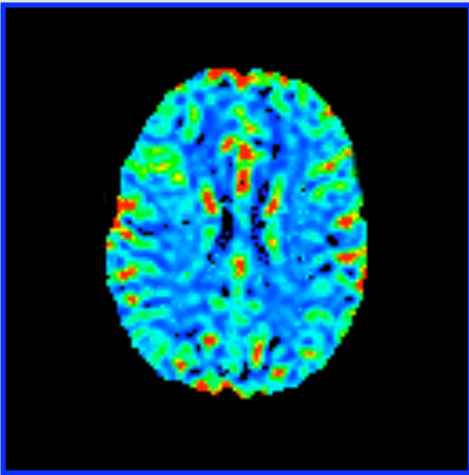

Perfusion

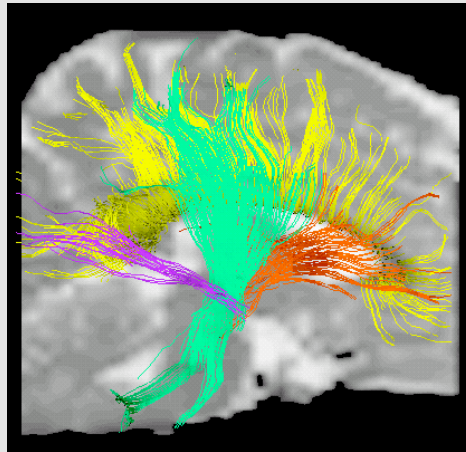

Diffusion

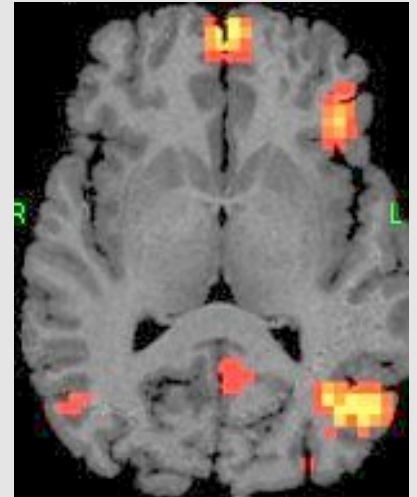

Functional

Color is *not* used for Multi-modality fusion

- Intention is to limit color use *in image* to where
 - Information is known added at acquisition
 - Involves pixel value replacement
 - Needs windowing of underlying grayscale
- Does not support transparency
- Separate new DICOM objects for
 - Spatial registration and fiducials
 - Blending presentation state for fusion
 - New enhanced multi-frame PET in development

Multi-modality fusion - Blending Presentation State

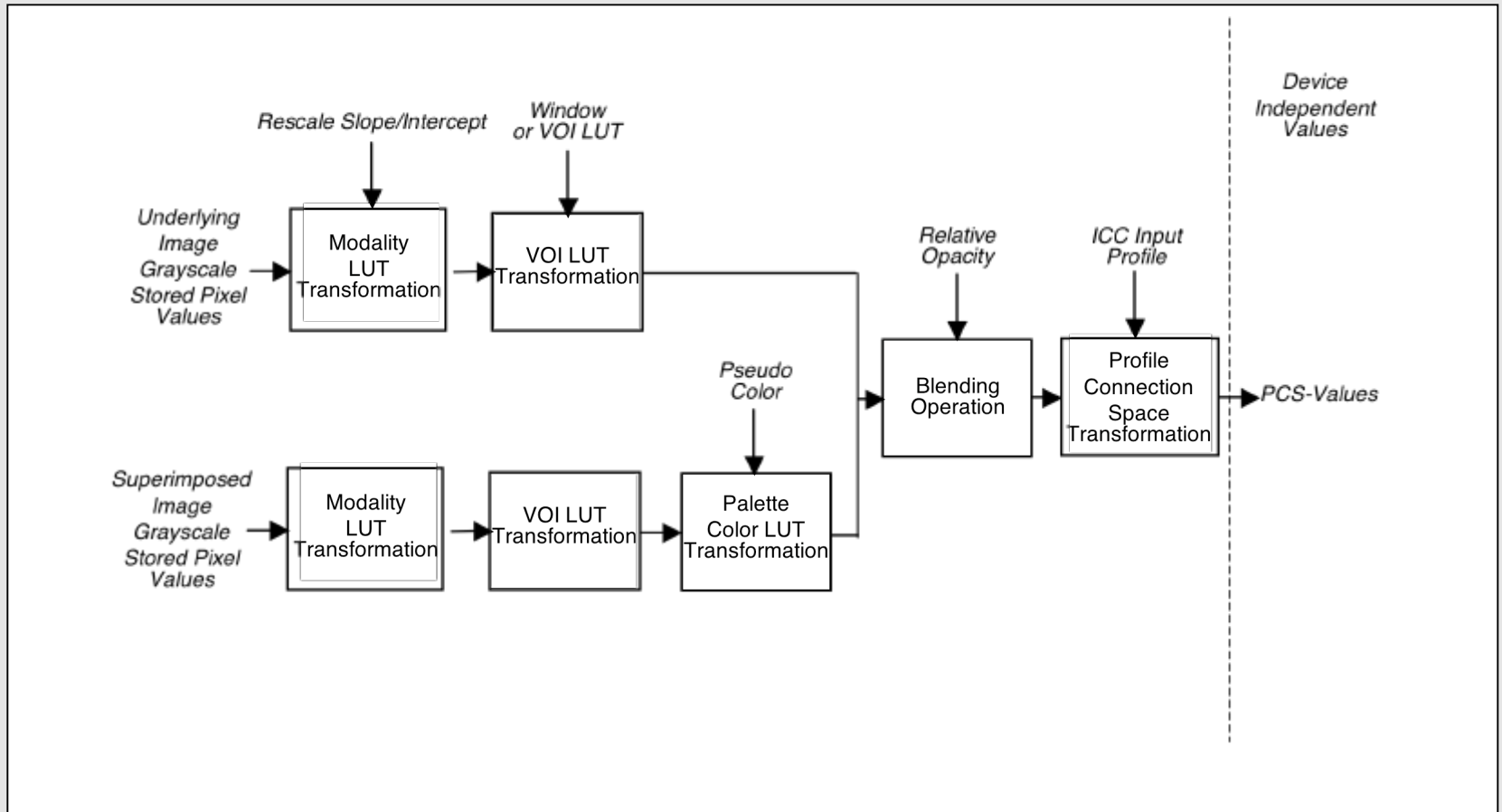

Blending for multi-modality fusion

**select
underlying**

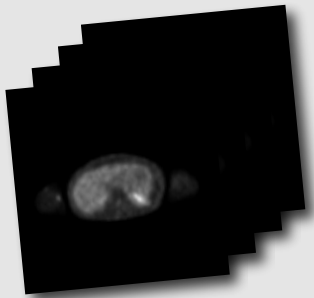
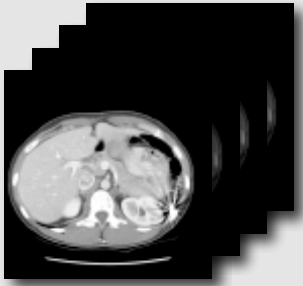

**select
superimposed**

Blending for multi-modality fusion

select
underlying

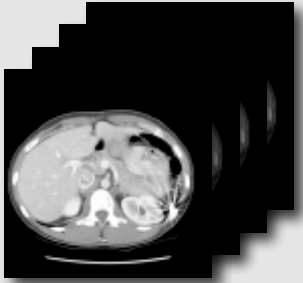

[register]

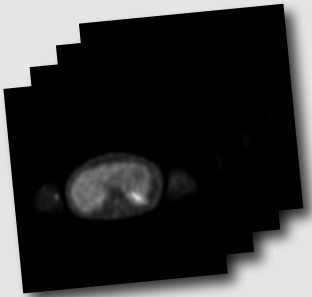
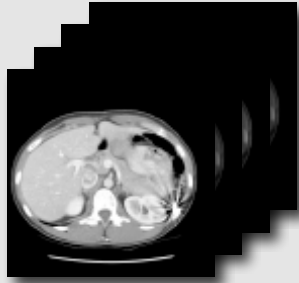

select
superimposed

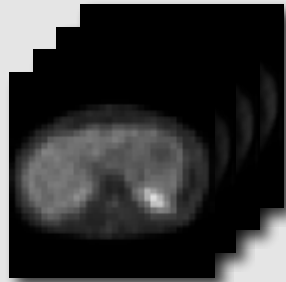

Blending for multi-modality fusion

select
underlying

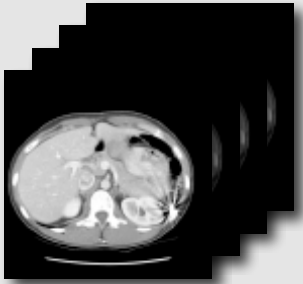

[register]

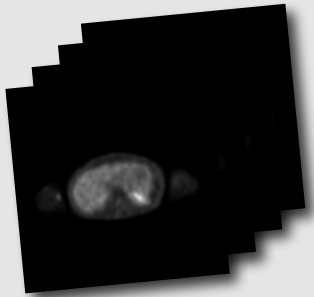
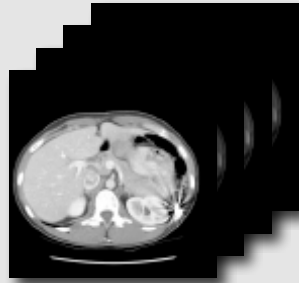

select
superimposed

resample

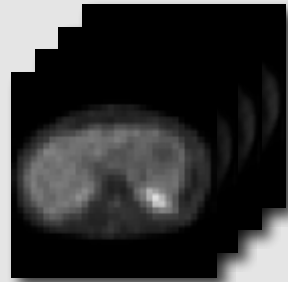

Blending for multi-modality fusion

select
underlying

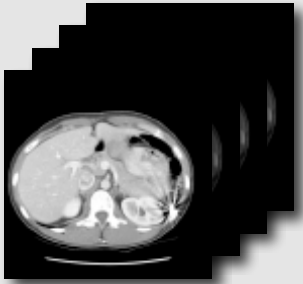

[register]

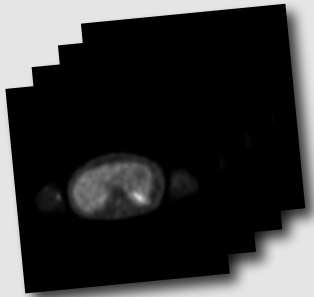
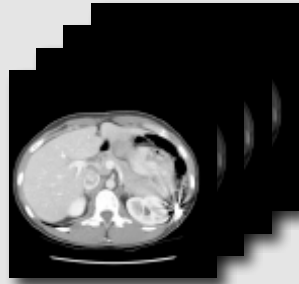

select
superimposed

resample

within slices

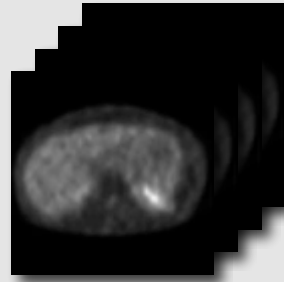
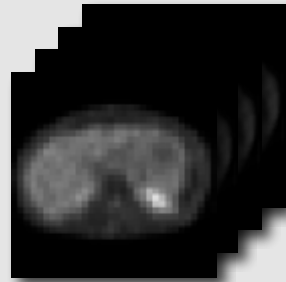

Blending for multi-modality fusion

select
underlying

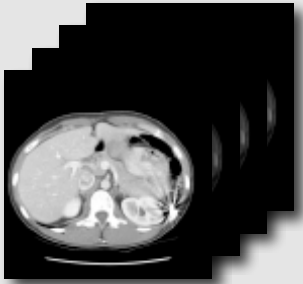

[register]

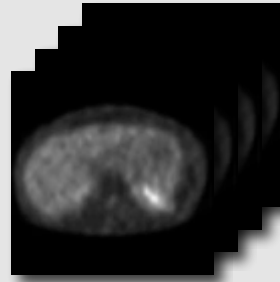
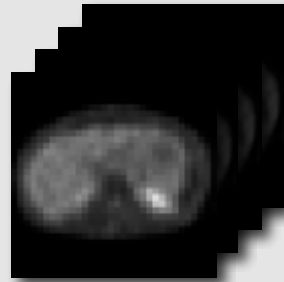
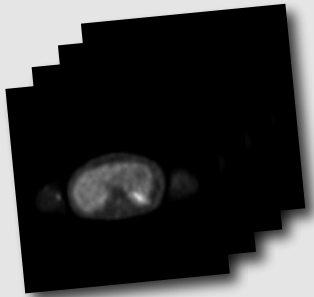
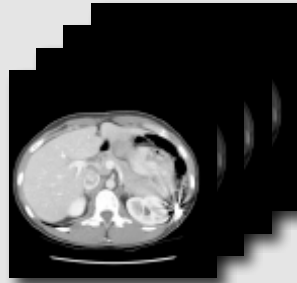

select
superimposed

resample

within slices

[between slices]

Blending for multi-modality fusion

select underlying

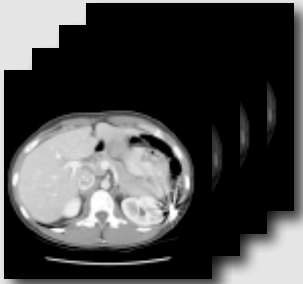

[register]

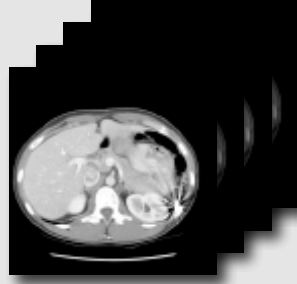

rescale and window

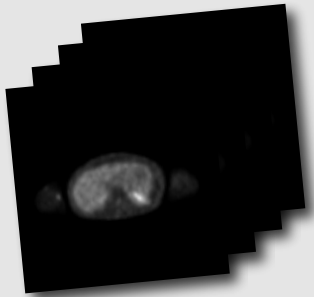
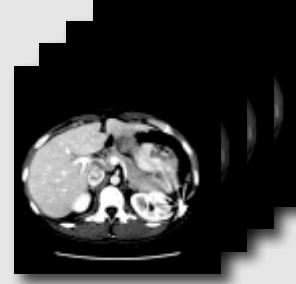

select superimposed

resample

within slices

[between slices]

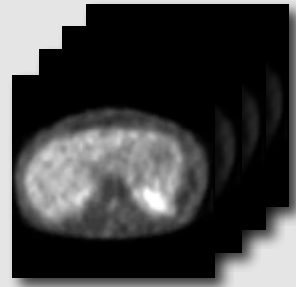
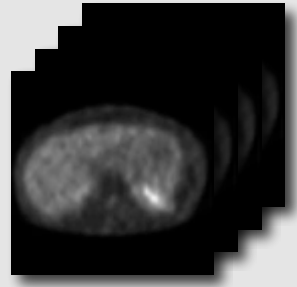
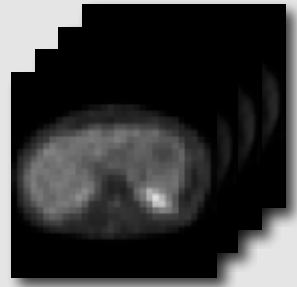

Blending for multi-modality fusion

select underlying

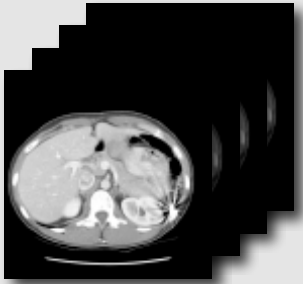

[register]

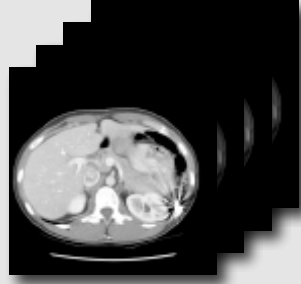

rescale and window

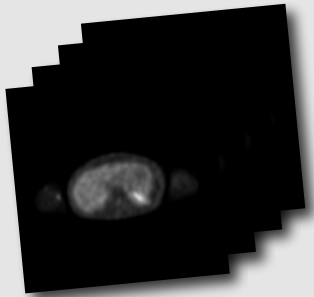
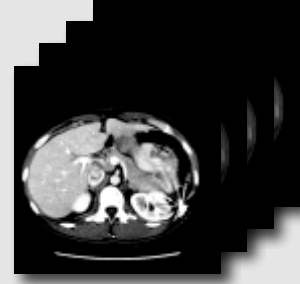

select superimposed

resample

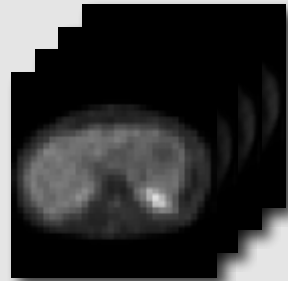

within slices

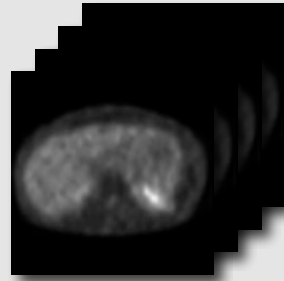

[between slices]

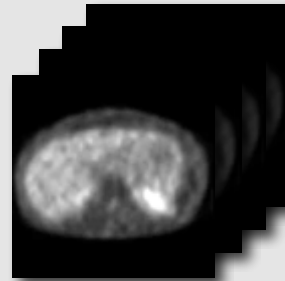

pseudo-color

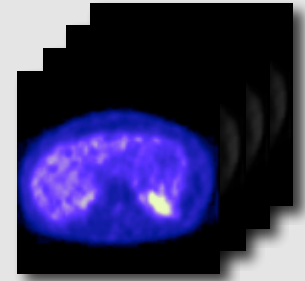

Blending for multi-modality fusion

select underlying

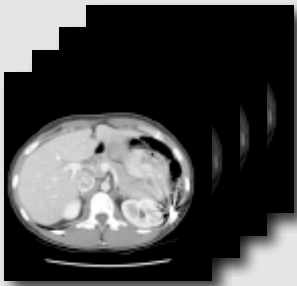

[register]

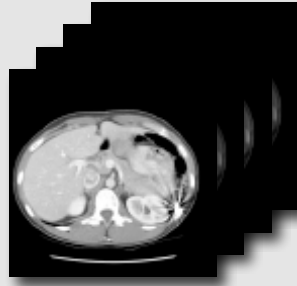

rescale and window

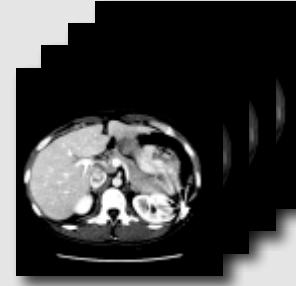

blend

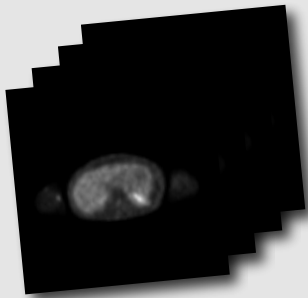
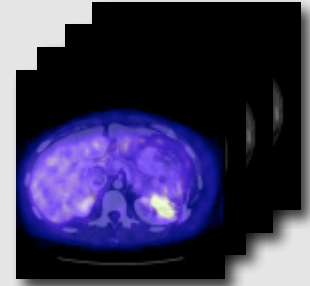

select superimposed

resample

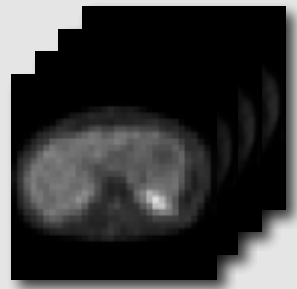

within slices

[between slices]

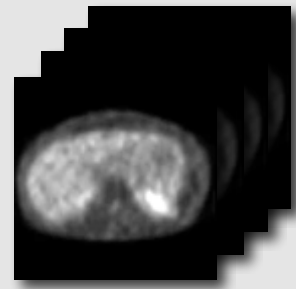
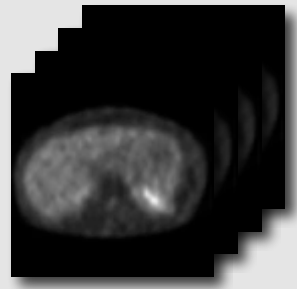

pseudo-color

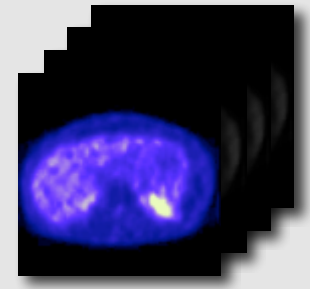

Spectroscopy

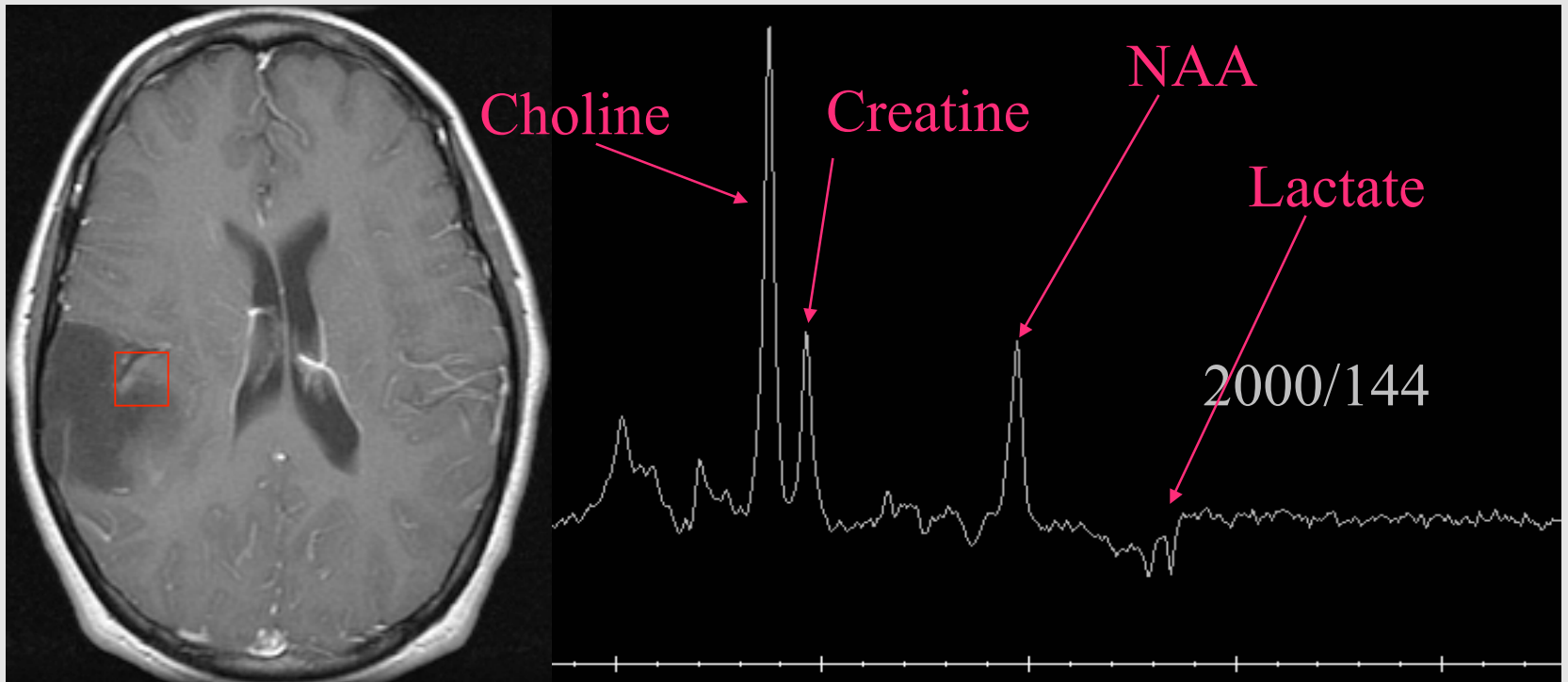

Metabolite Maps

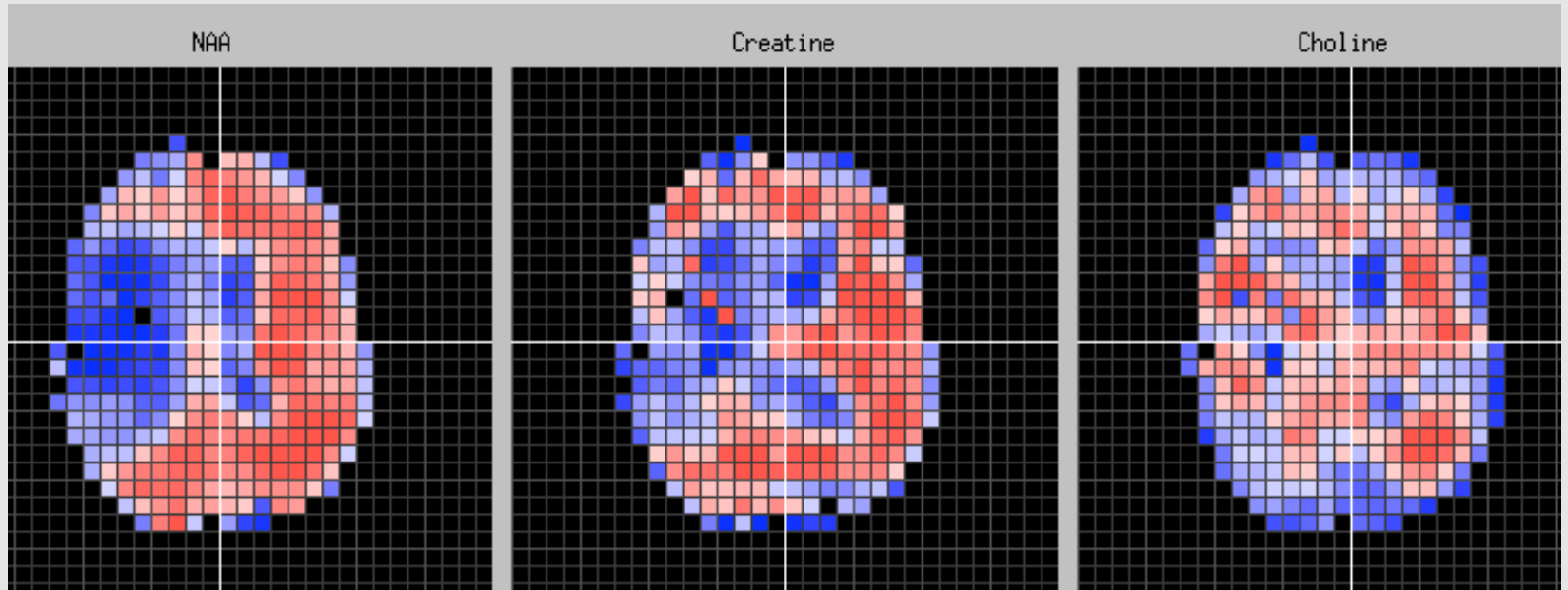

MR Spectroscopy

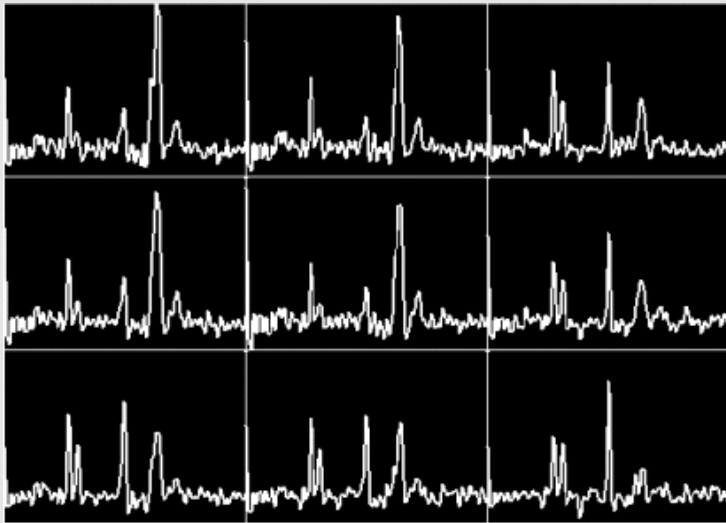

Storage of
Spectroscopy Data

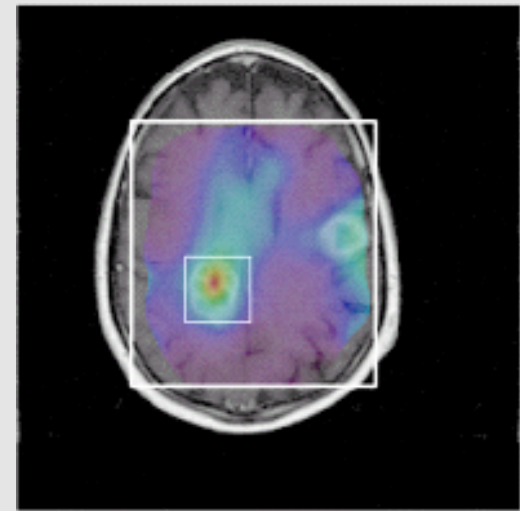

Metabolite Maps

MR Spectroscopy

- Two types of data
 - Spatially localized spectra (signal intensity versus frequency or time)
 - Images of one particular part of the spectrum (chemical shift image or metabolite map)
- Metabolite maps are stored as images
- Spectra cannot be not stored as pixel data
- In the past - stored as screen saves of curves
- Now - MR Spectroscopy SOP Class
 - Arrays of floating point and/or complex values
 - 1D or 2D data for single or multiple voxels and frames
 - Allows for interaction, analysis and quantitation

DICOMDIR Image Spectra Attributes Frames

File... Import Send... XML... Validate...

Frame index: 1 8

Sort frames by: implicit dimension

1 [124 frames] [MR(MF,T1) <AXIAL L\P>
1 [32 frames] [MR(MF,FLUID_ATTENUATED) <AXIAL L\P>

1 [124 frames] [MR(MF,T1) <AXIAL L\P>
1 [32 frames] [MR(MF,FLUID_ATTENUATED) <AXIAL L\P>
2 [MR(MF,DERIVED,T1,RESAMPLED,MPR) <SAGITTAL P\F>

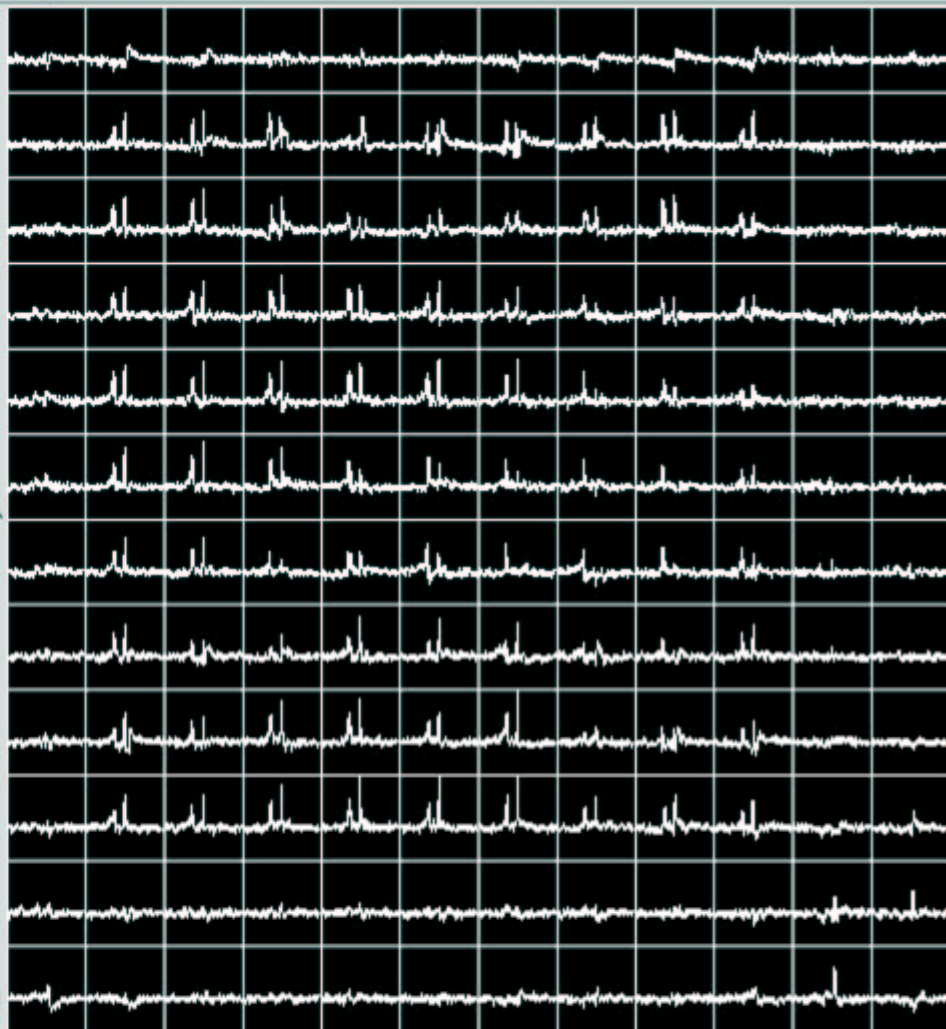

Frame	AccessionNumber	AcquisitionContrast	AcquisitionDateTim	AcquisitionDuration	AcquisitionNumber	ApplicableSafetyStandardAgency	BaselineCorrect
4	9995025	UNKNOWN	20020728125300	600	100	FDA	NONE



Dicom Image Viewer

DICOMDIR Image Spectra Attributes Frames

File... Import Send... XML... Validate...

Frame index: 1 8

Sort frames by: implicit dimension

- 1 [124 frames] [MR(MF),T1] <AXIAL L\P>
- 1 [32 frames] [MR(MF),FLUID_ATTENUATED] <AXIAL L\P>
- 1 [124 frames] [MR(MF),T1] <AXIAL L\P>
- 1 [32 frames] [MR(MF),FLUID_ATTENUATED] <AXIAL L\P>
- 2 [MR(MF),DERIVED,T1,RESAMPLED,MPR] <SAGITTAL P\F>

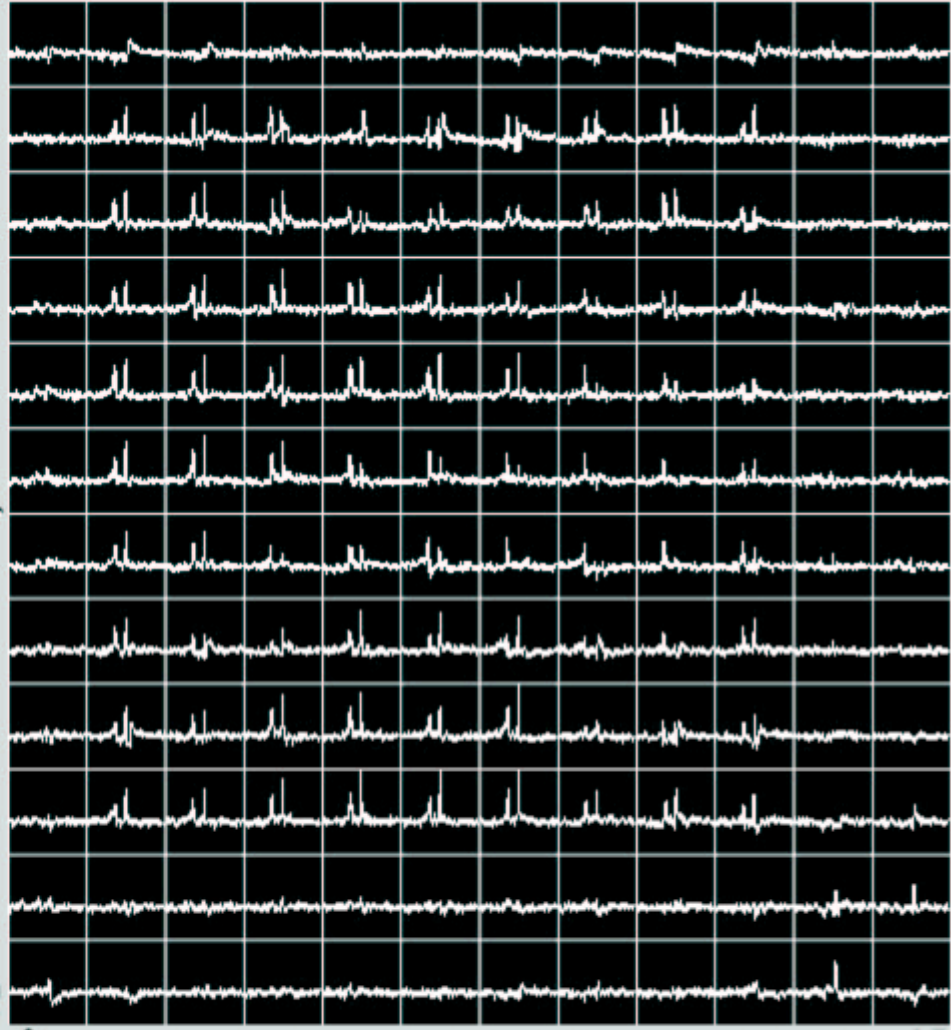
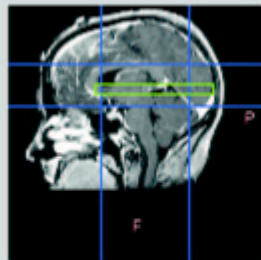

Frame	AccessionNumber	AcquisitionContrast	AcquisitionDateTim	AcquisitionDuration	AcquisitionNumber	ApplicableSafetyStandardAgency	BaselineCorrect
4	9995025	UNKNOWN	20020728125300	600	100	FDA	NONE



Done.



Dicom Image Viewer

DICOMDIR Image Spectra Attributes Frames

File... Import Send... XML... Validate...

Frame index: 1 8

Sort frames by: implicit dimension

1 [124 frames] [MR(MF),T1] <AXIAL L\P>
1 [32 frames] [MR(MF),FLUID_ATTENUATED] <AXIAL L\P>

1 [124 frames] [MR(MF),T1] <AXIAL L\P>
1 [32 frames] [MR(MF),FLUID_ATTENUATED] <AXIAL L\P>
2 [MR(MF),DERIVED,T1,RESAMPLED,MPR] <SAGITTAL P\F>

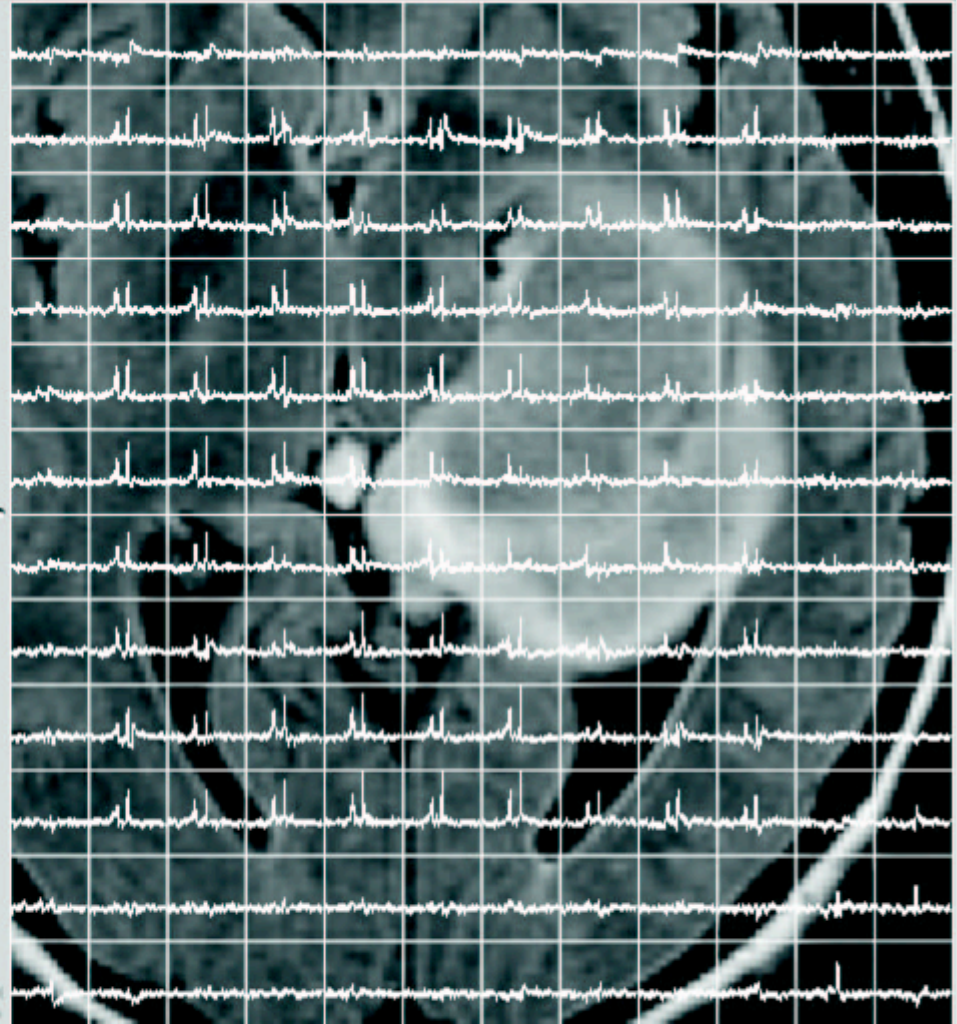
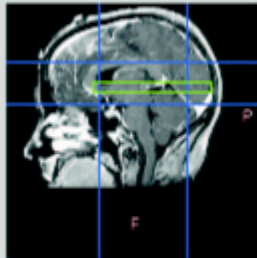

Frame	AccessionNumber	AcquisitionContrast	AcquisitionDateTim	AcquisitionDuration	AcquisitionNumber	ApplicableSafetyStandardAgency	BaselineCorrect
4	9995025	UNKNOWN	20020728125300	600	100	FDA	NONE

(7:172,4)

Raw Data

- MR and CT have “raw data” prior to reconstruction into spatial domain images (k-space data, raw views)
- Need for different reconstructions
 - Slice thickness and reconstruction interval
 - Different convolution kernel (bone, lung)
 - Different field of view
 - For CAD versus human viewing
- Raw data is bulky and proprietary
- Local long term archival on modality possible but unusual and inconvenient, therefore time window for retrospective reconstruction is limited

Raw Data SOP Class

- Goal is storage of encapsulated raw data in the PACS or other central archive
- Without standardizing raw data format
- Defines usual patient, study, series, instance attributes
- No standard payload - raw data assumed to be in private attributes
- Allows for storage and retrieval without understanding
- No expectation that different vendors will be able to use the data
- SOP Instance UID of raw data can be referenced from images and spectra

Performance Opportunities

- New multi-frame object does not change
 - TCP connection establishment
 - Association establishment
- Common header information is not repeated
 - But reduction is negligible compared to pixel data size
- Reduced latency (delay) between storage requests
- Fewer database insertions
 - One entry in image table versus one per slice
- Creates opportunity for inter-slice (3D) compression
- Extremely implementation-dependent

A
s
s
o
c
i
a
t
i
o
n



C-Store request



Dataset (attributes+pixels)



C-Store response (acknowledgement)

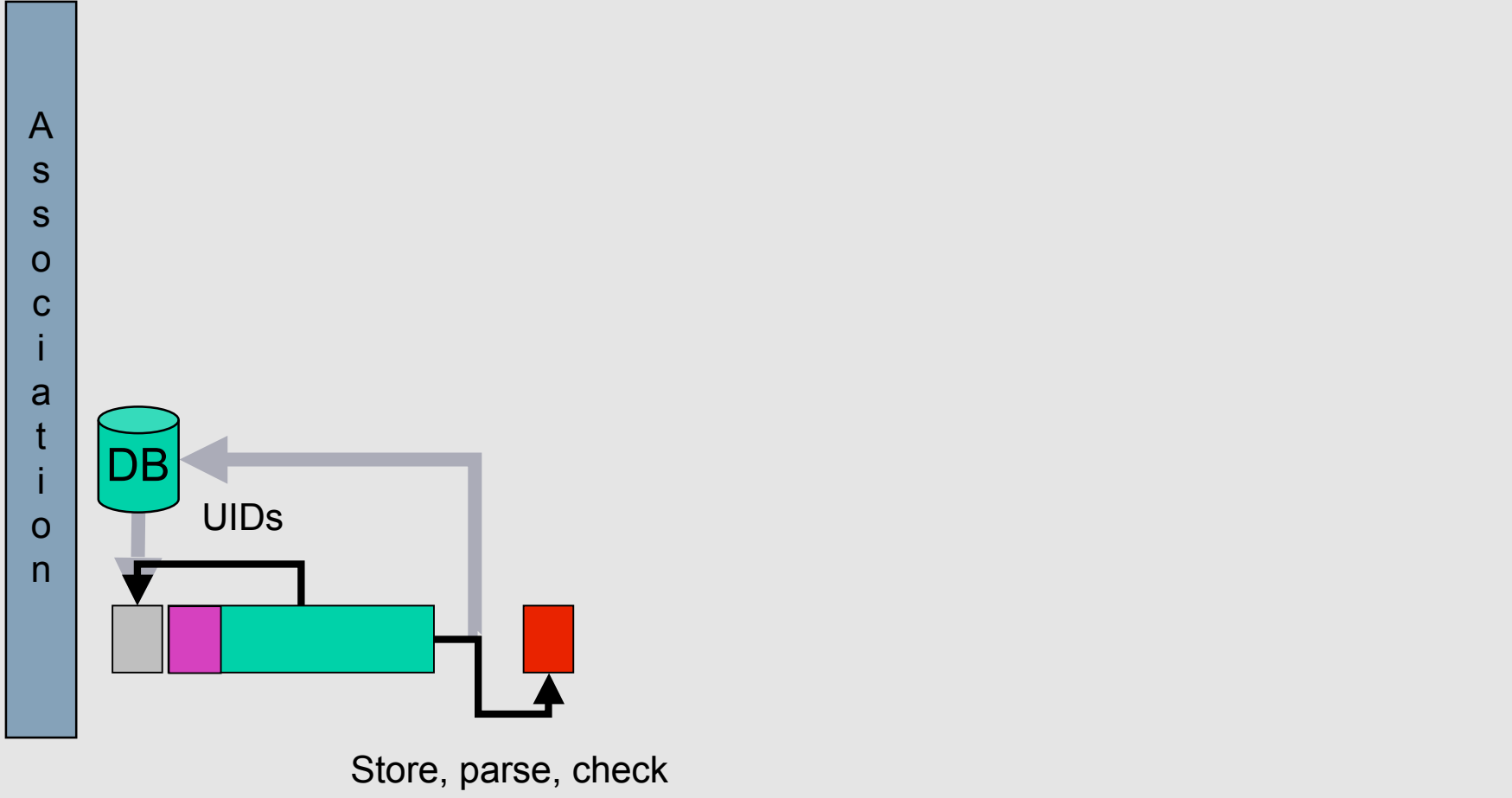

C-Store request



Dataset (attributes+pixels)



C-Store response (acknowledgement)

A
s
s
o
c
i
a
t
i
o
n

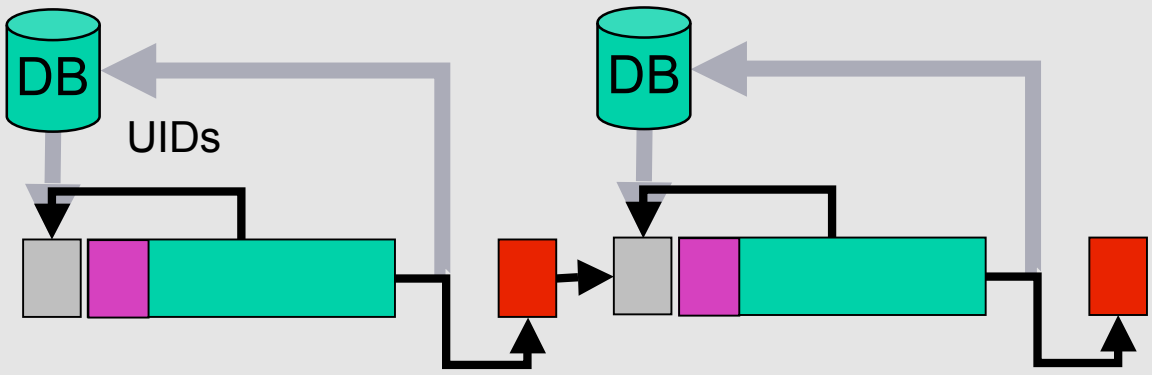

Store, parse, check



C-Store request

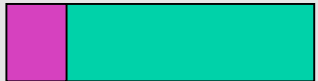

Dataset (attributes+pixels)



C-Store response (acknowledgement)

A
s
s
o
c
i
a
t
i
o
n

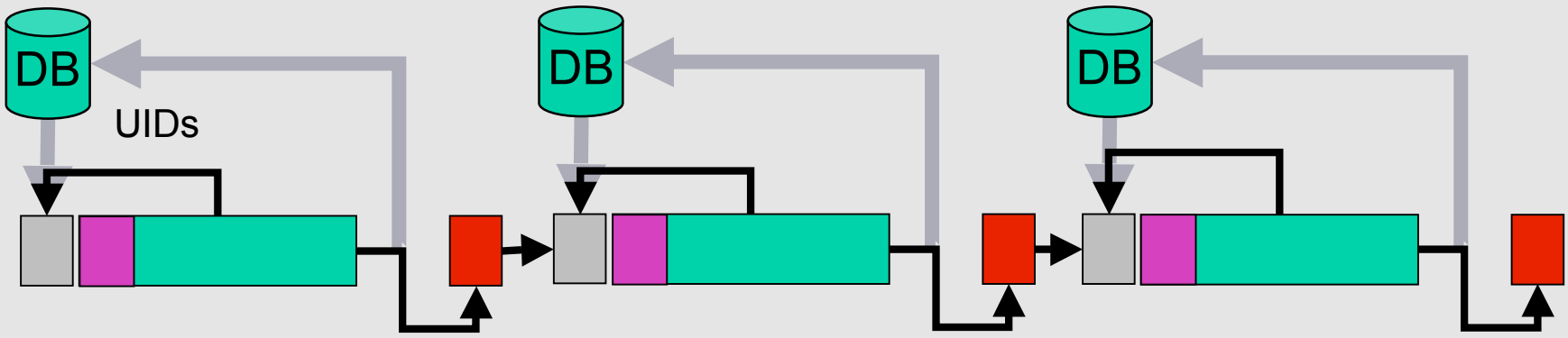

Store, parse, check



C-Store request

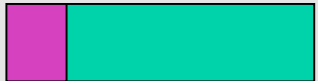

Dataset (attributes+pixels)



C-Store response (acknowledgement)

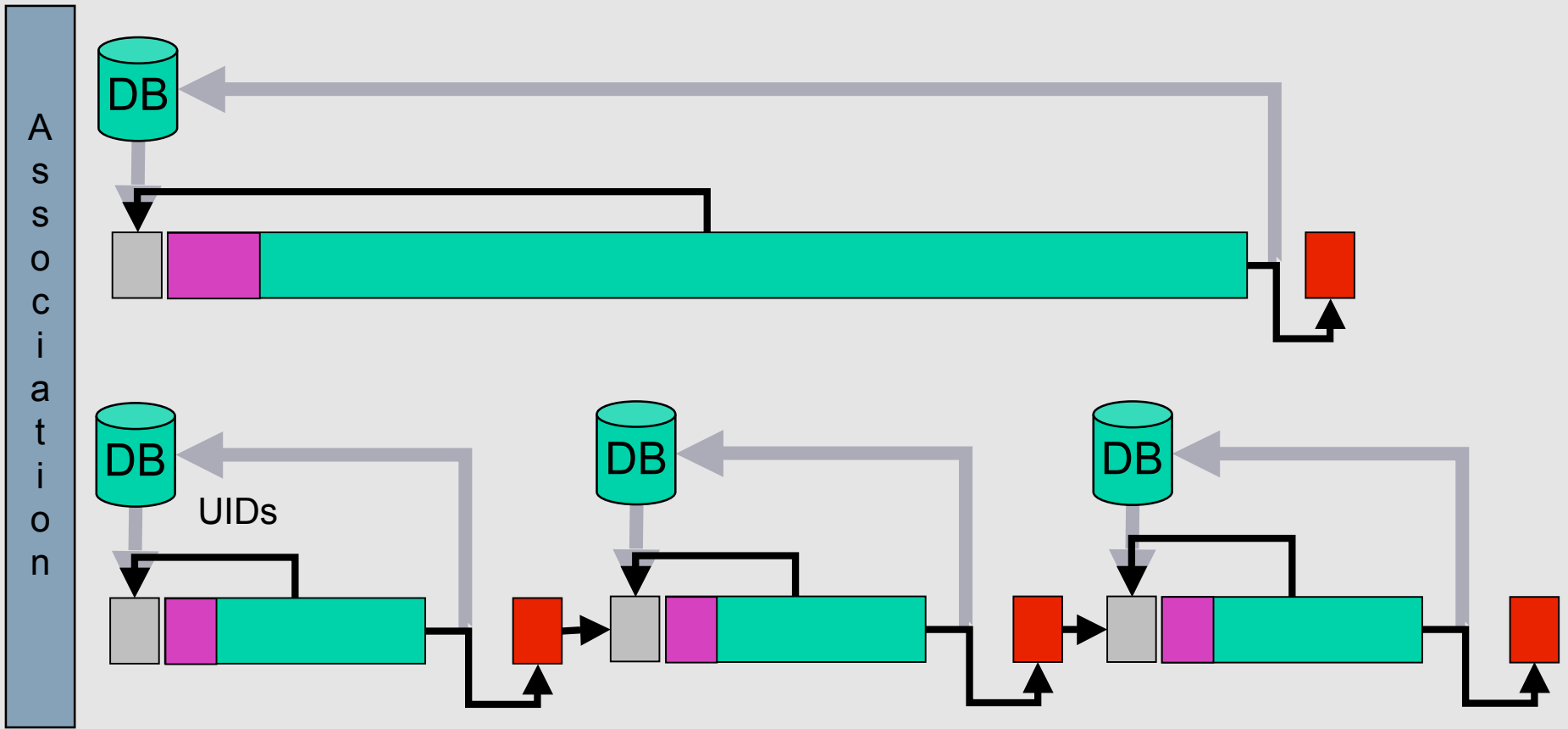

Store, parse, check



C-Store request



Dataset (attributes+pixels)



C-Store response (acknowledgement)

CTA - 548x512x512 (275MB) File read/transfer/save (GB Ethernet)

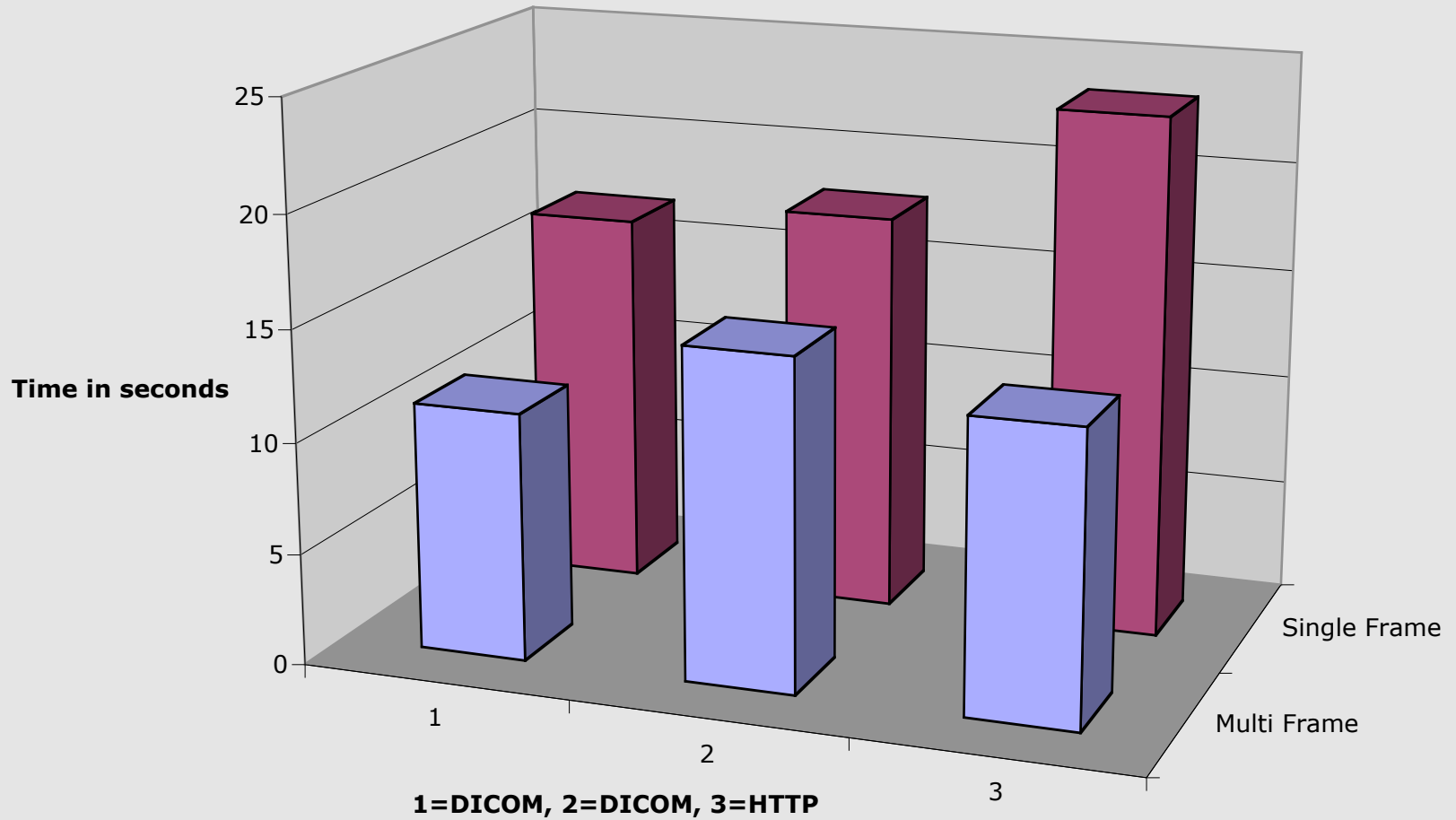

	1	2	3
Multi Frame	11.14111111	14.86703704	13.07333333
Single Frame	16.905	17.97	23.42666667

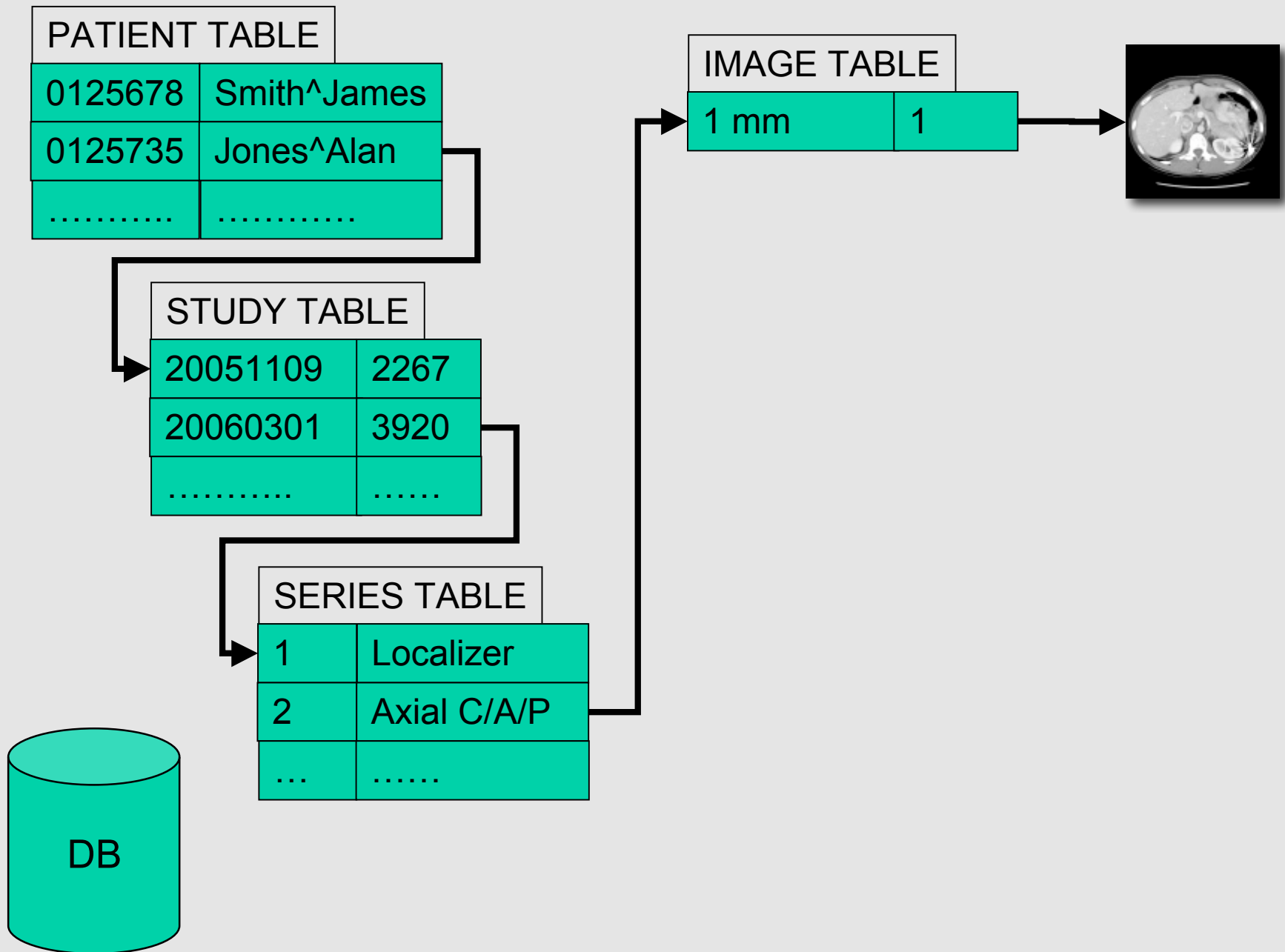

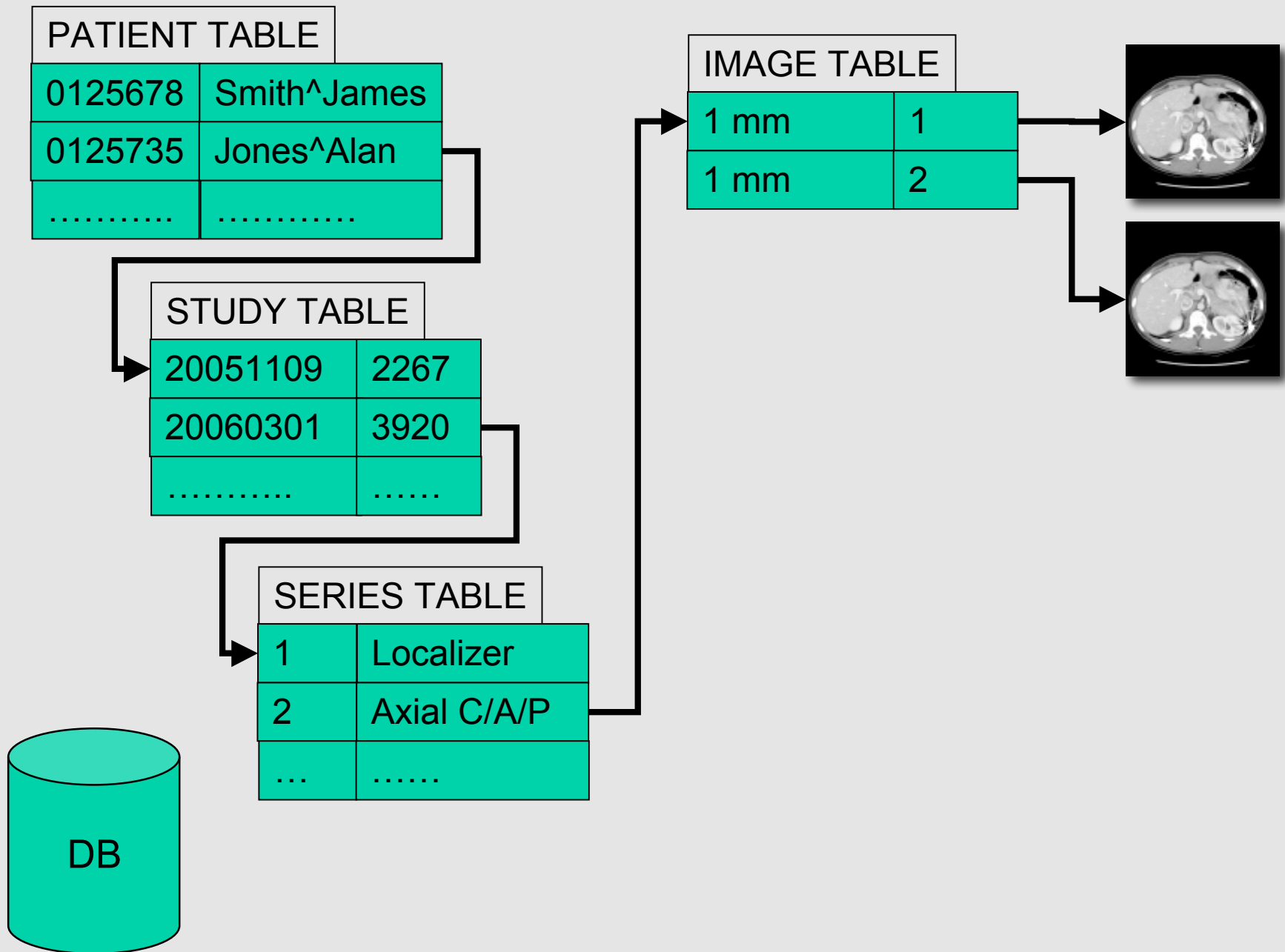

PATIENT TABLE

0125678	Smith^James
0125735	Jones^Alan
.....

STUDY TABLE

20051109	2267
20060301	3920
.....

SERIES TABLE

1	Localizer
2	Axial C/A/P
...

IMAGE TABLE

1 mm	1
------	---

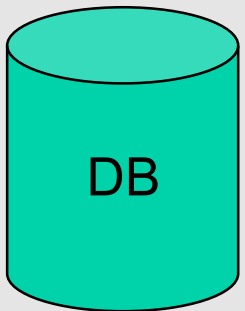
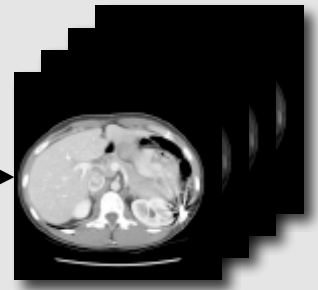

Single database insertion - just don't need per-slice detail in database

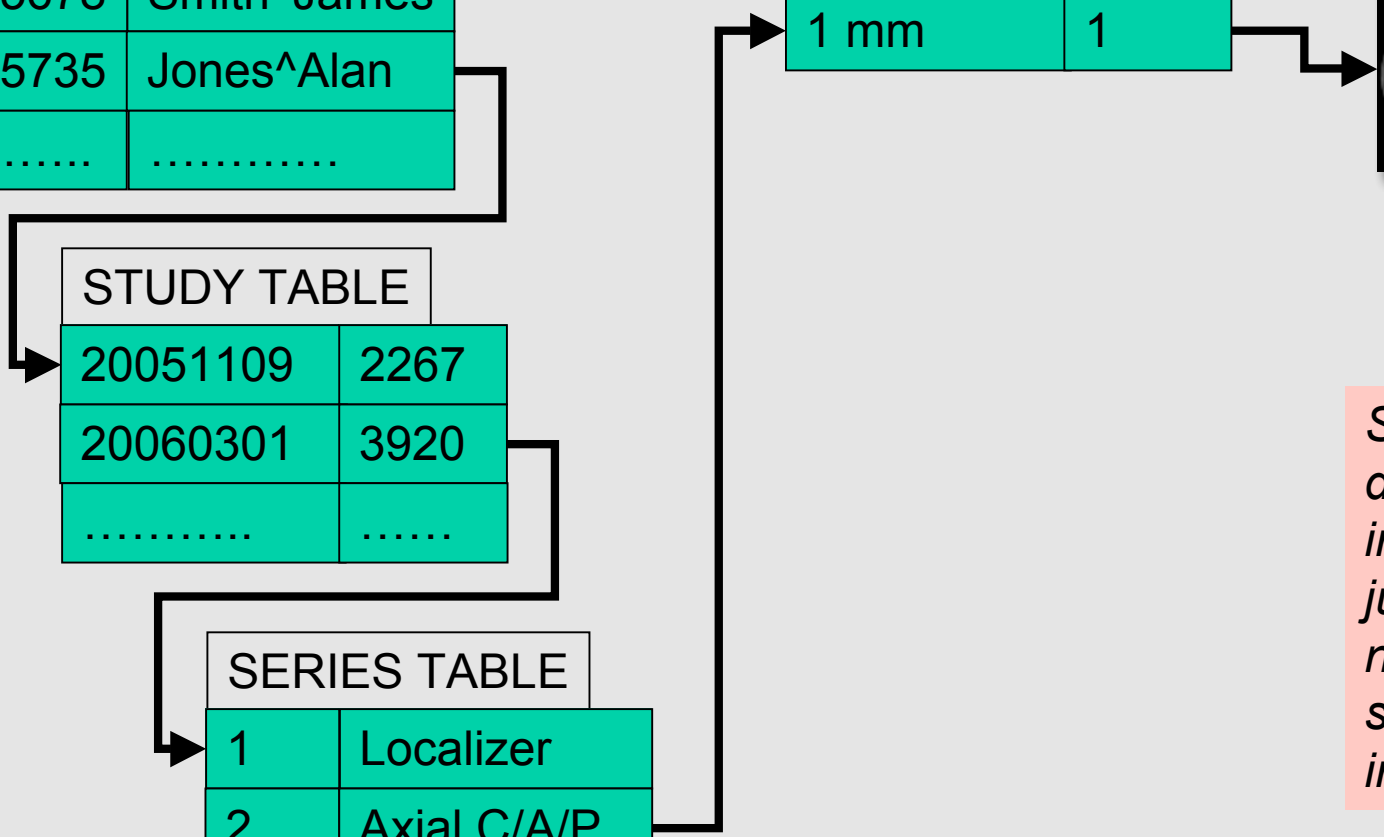

Multi-frame compression

- Original CT and MR SOP Classes are single frame
 - Compression only possible within a single frame
 - Lossless - typically 3:1 or 4:1 for CT and MR
- Multi-frame objects
 - Opportunity to take advantage of redundancy between frames
 - Spatial redundancy - JPEG 2000 Part 2
 - Lossless gain modest, lossy gain more substantial
 - Motion prediction - MPEG-2 and others
 - New schemes - H.264/MPEG-4 Part 10
 - Entire dataset (e.g., 3D volume) or adjacent slabs

Single frame lossless compression

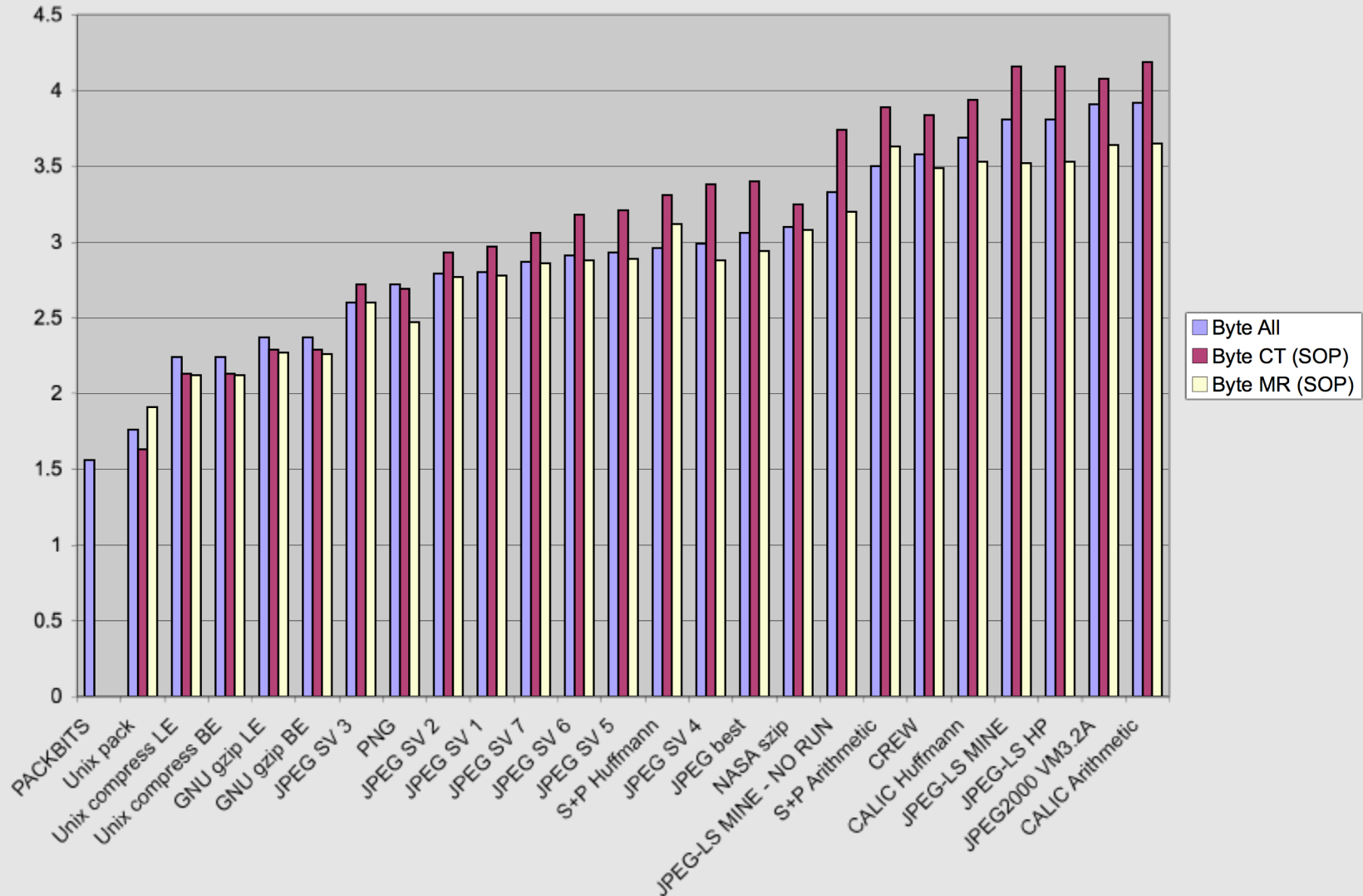

Single frame lossless compression

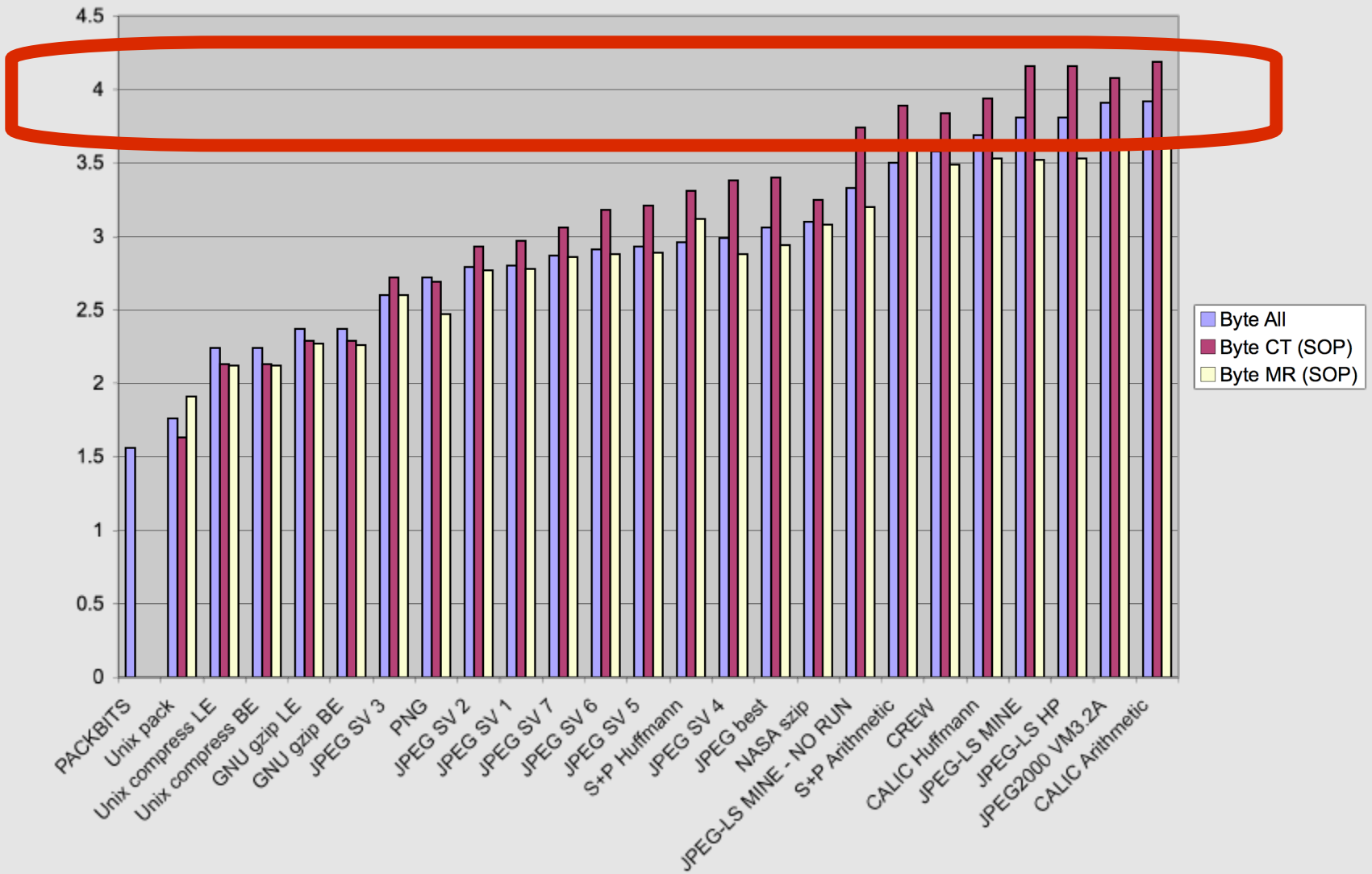

Lossless JPEG 2000 Compression (Alexis Tzannes, Aware, 2003)

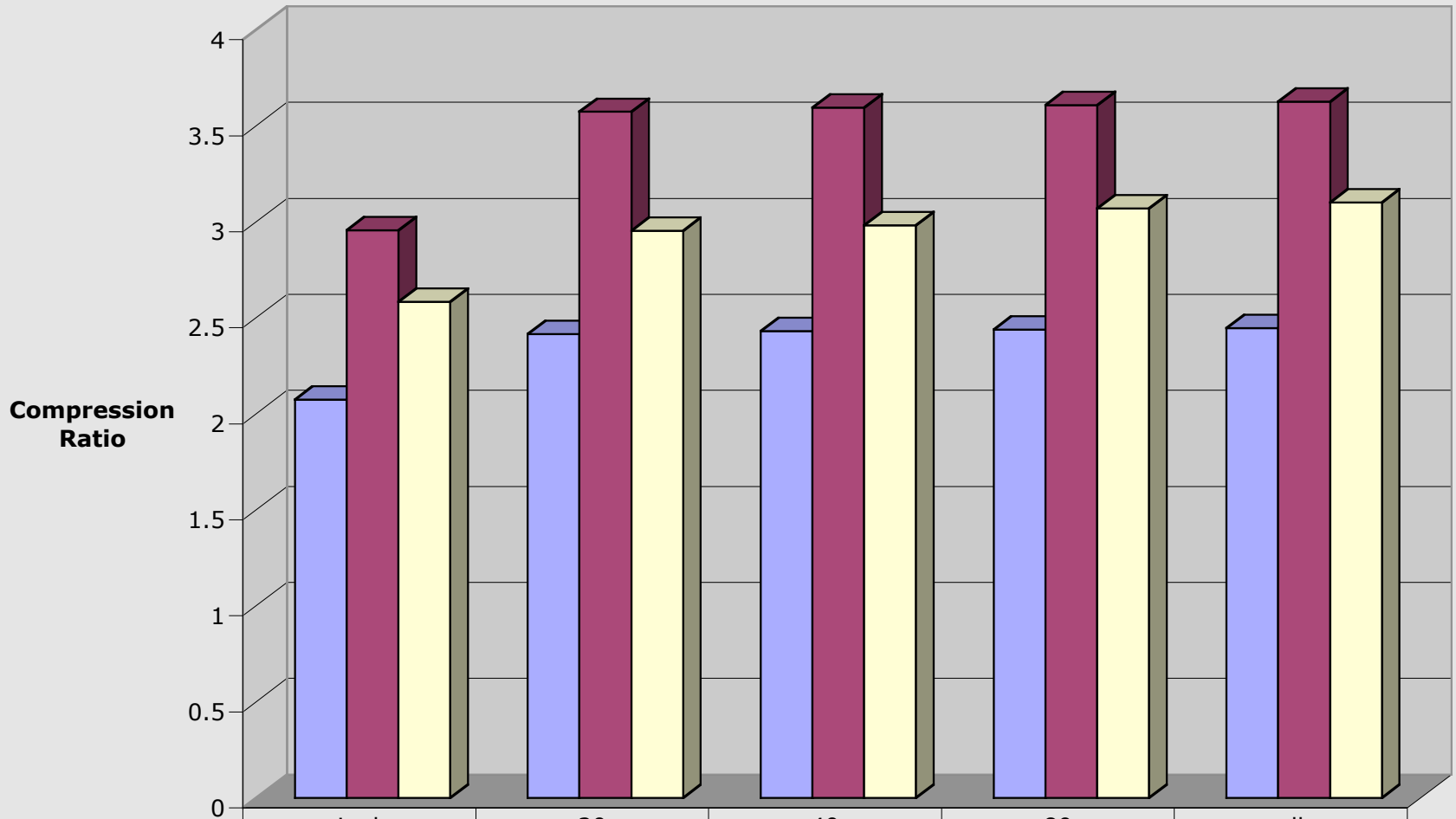

	single	20	40	80	all
127x256x8 7.9MB	2.073490814	2.415902141	2.430769231	2.438271605	2.445820433
449x512x16 224MB	2.955145119	3.572567783	3.595505618	3.607085346	3.624595469
620x512x16 310MB	2.583333333	2.952380952	2.980769231	3.069306931	3.1

Slices in 3rd dimension

Lossless JPEG 2000 Compression (Alexis Tzannes, Aware, 2003)

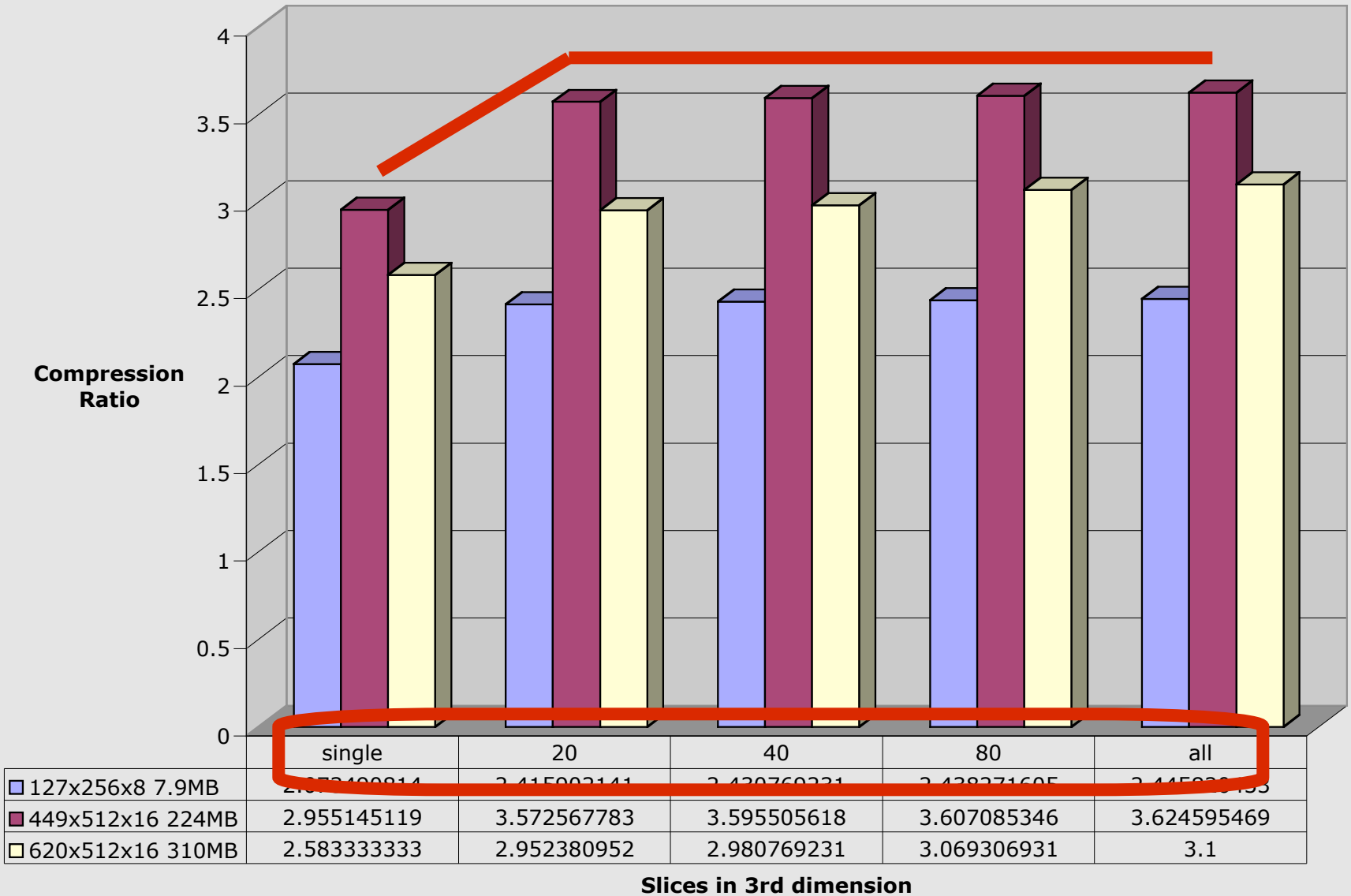

Lossy 3D JPEG 2000 Compression (Alexis Tzannes, Aware, 2003)

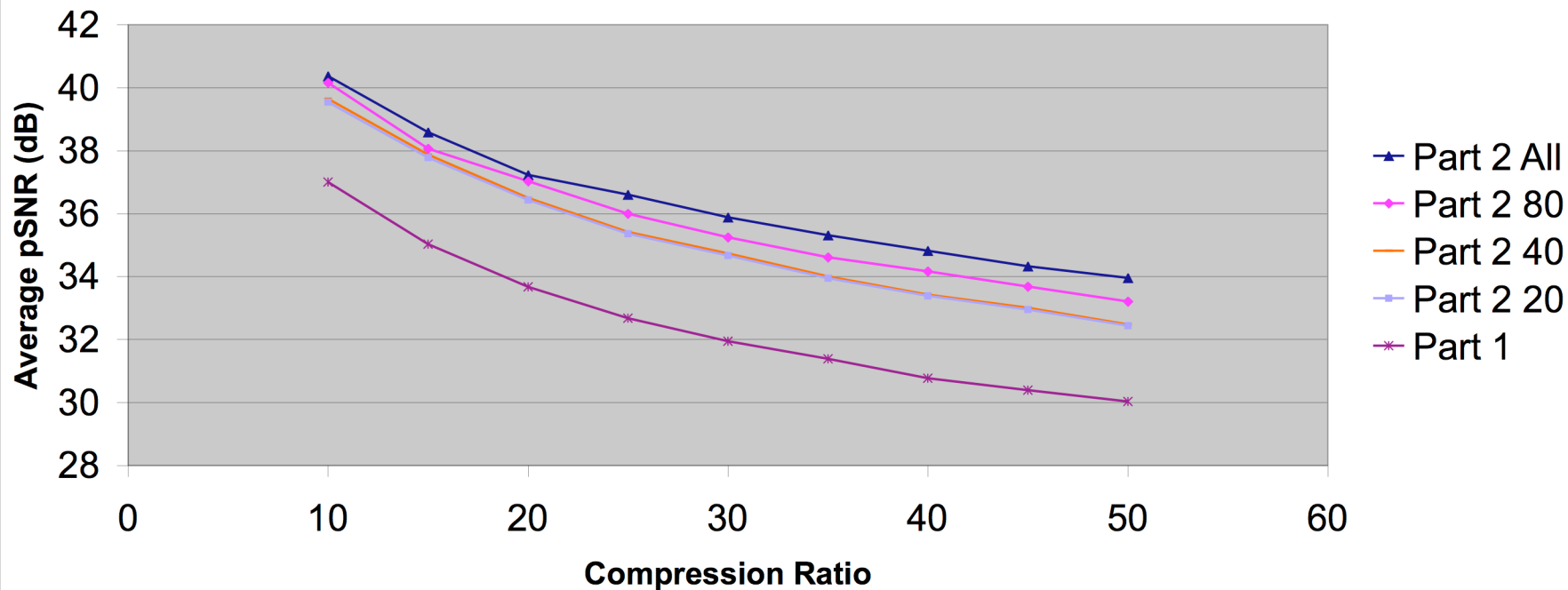

Lossy 3D JPEG 2000 Compression (Alexis Tzannes, Aware, 2003)

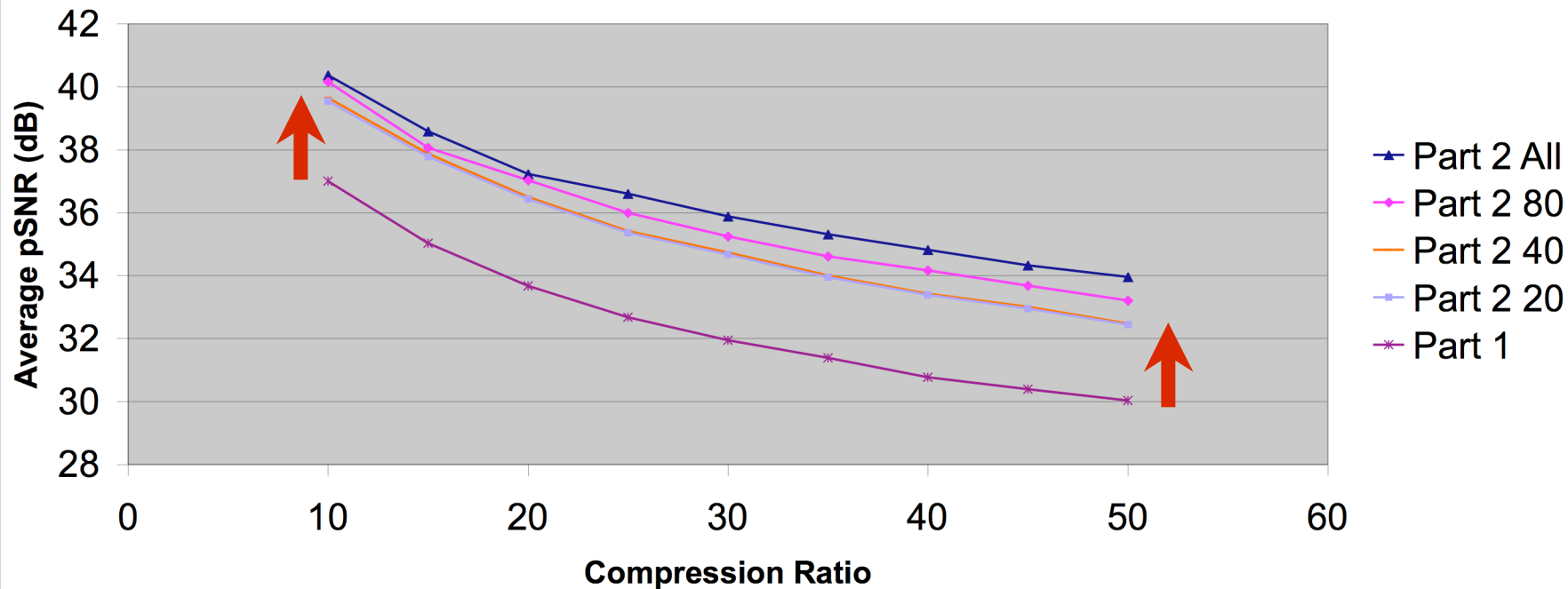

2D JPEG 2000 0.625mm slices



8:1



16:1



32:1

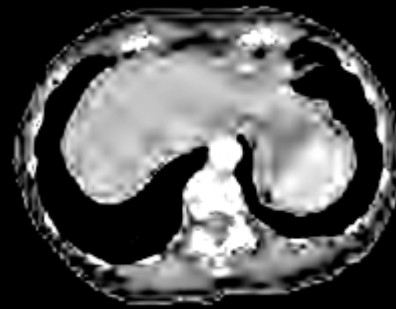

160:1

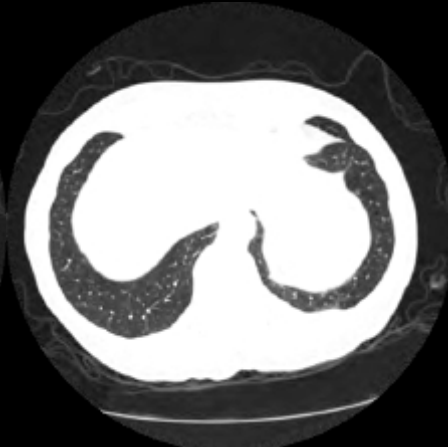
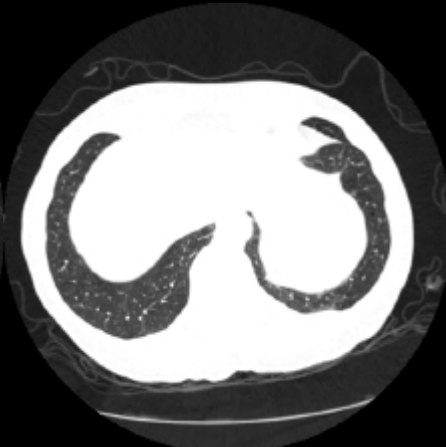
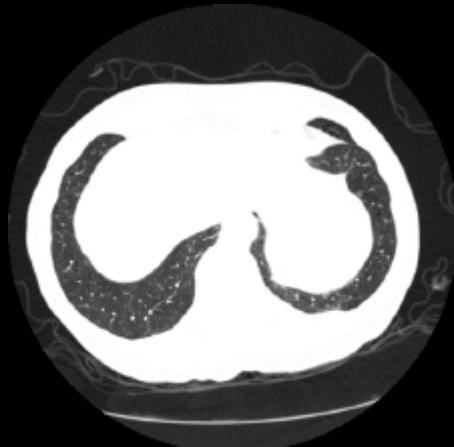

1:1



8:1



16:1

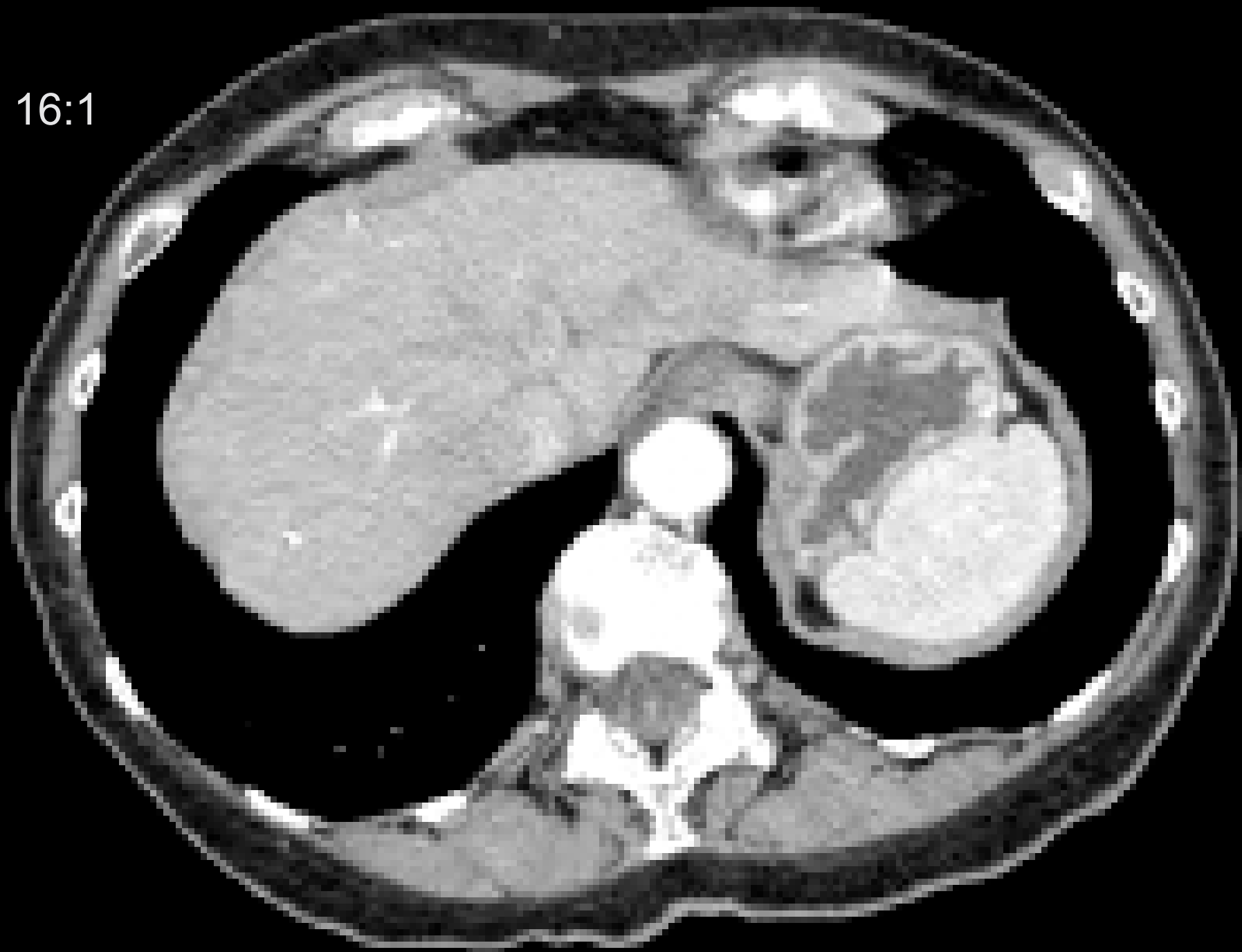

16:1 3D



1:1



32:1



160:1

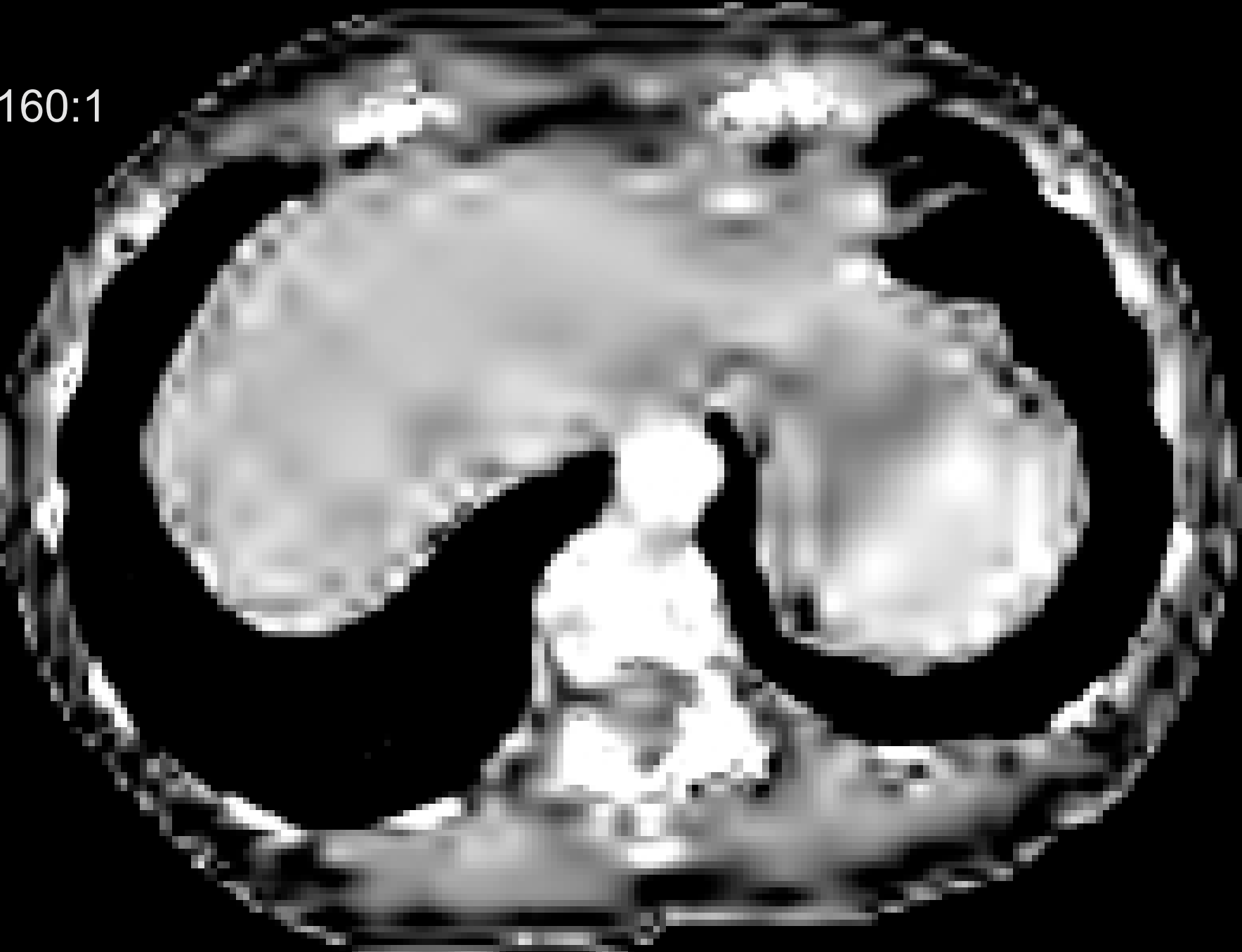

Multi-frame compression performance reality check

- Lossless compression in 3D
 - Slight gain - 15 to 20% smaller than 2D
- Lossy compression in 3D
 - Modest gain - possibly 50% smaller than 2D
 - But - only relatively modest loss before noticeable
 - Perhaps (?) 16:1
- Siddiqui et al, SCAR 2004
 - Thinner slices compress poorly due to noise
 - 3D JPEG 2000 compression may be used to compensate
- Need more experiments
 - Effect on observer performance unknown

But when ?

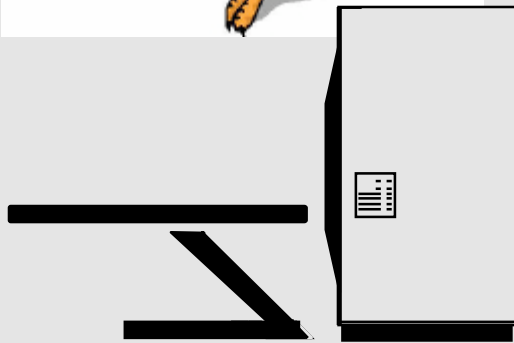
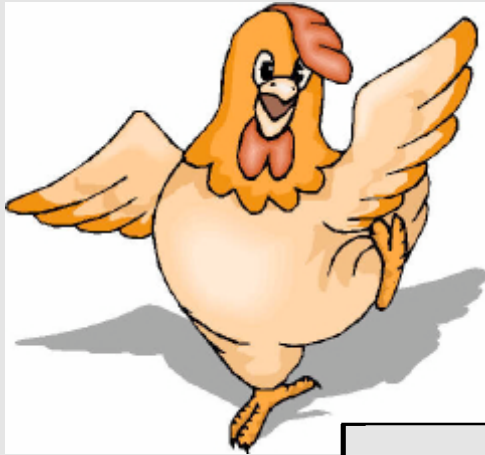

Modality

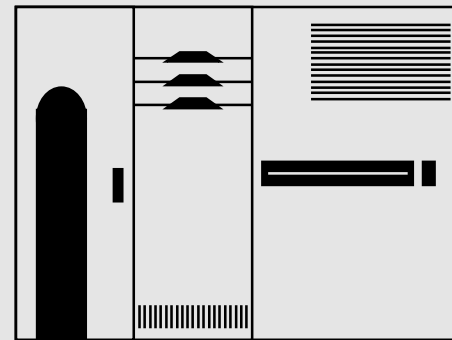

PACS

NEMA Initiatives

- MR test tools, images and spectra available
- CT test tools and images available
- Implementation testing & demonstration
 - June 2005 - SCAR demonstration
 - November 2005 - RSNA InfoRAD demonstration

NEMA & SCAR Test & Demonstration



Purpose of the Test & Demonstration

- Participants
 - Test that it works
 - Identify problems and solutions
- Other vendors
 - Show what work needs to be done
- Users
 - Show that it works
 - Begin to show some of the benefits
 - Performance
 - Interoperability of new attributes, dimensions, applications, spectroscopy ... testing of clinical scenarios

Enhanced objects in products

- Google survey of conformance statements (Cor Loef, Philips, Nov 2006)
 - MR - 25 devices (2 modalities - Philips, Toshiba (?))
 - CT - 9 devices (1 modality - Toshiba)
- MR spectroscopy
 - 2 modalities (Philips, Siemens)
- Remains for workstation applications to take advantage of new features

Enhanced objects not just for MR & CT ...

- PET
 - Currently single slice
 - Driven by renewed interest in PET-CT fusion
 - Work in progress
- X-ray angiography and RF
 - Support for digital detectors
 - New acquisition types
- 3D X-ray
 - Rotational angio, tomosynthesis and cone beam CT
 - Work in progress
- 3D Ultrasound
 - Work in progress

Conclusion

- New DICOM image and other objects to address new applications & technology
- Greater inter-functionality for more complex clinical scenarios and applications
- Performance opportunities for large data volumes